

LCM 3 50ft Landing Craft

UK

This landing craft was used extensively by US and British navies during the Second World War to transport wheeled vehicles, lightweight armour and materials (weighing up to 30 tons) from ship to shore. Over 8000 LCM model 3 landing craft were produced, being built in numerous shipyards in the USA from 1942 up to the end of the conflict. It would later be used by western allies of the United States up until the 1980s.

F

Cet engin de débarquement fut intensément utilisé par les Marines américaines et anglaises au cours du second conflit mondial pour le transport depuis les navires de chargement jusqu'aux plages des véhicules sur roues, blindés légers et matériels jusqu'à un poids maximum de 30 tonnes. L'LCM modèle 3 fut produit en plus de 8000 exemplaires, construits dans de nombreux chantiers des Etats Unis d'Amérique entre 1942 et la fin de la guerre. Ensuite, cette embarcation fut utilisée par les pays occidentaux alliés de l'Amérique jusqu'aux années 80.

I

Questo mezzo da sbarco fu estesamente utilizzato dalle Marine americane ed inglesi nel corso del Secondo Conflitto Mondiale per il trasporto dalle navi da carico alle spiagge di veicoli ruotati, mezzi corazzati leggeri e materiali sino ad un peso massimo di 30 tonnellate. L'LCM modello 3 fu prodotto in oltre 8000 esemplari, costruiti presso numerosi cantieri degli Stati Uniti d'America dal 1942 sino al termine della Guerra. Negli anni successivi questo natante fu utilizzato dai paesi occidentali alleati dell'America sino agli anni '80.

NL

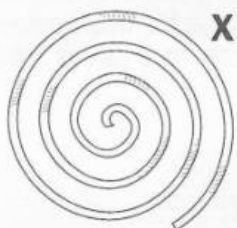
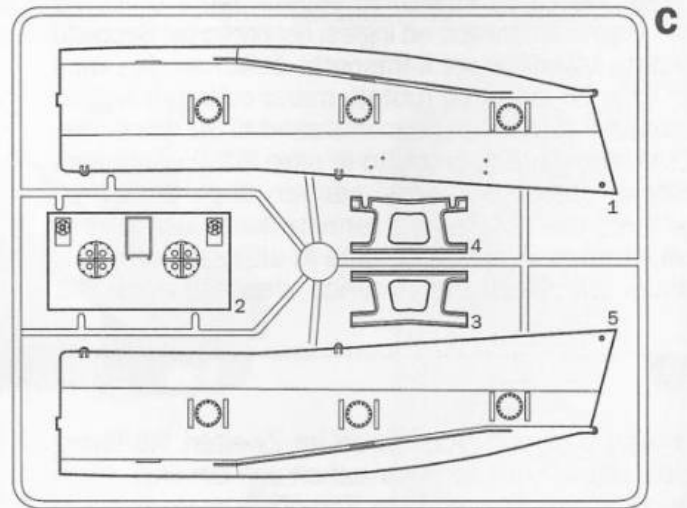
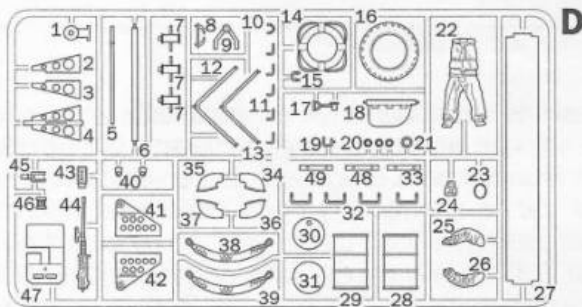
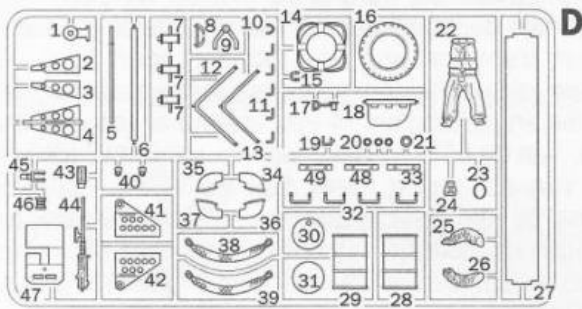
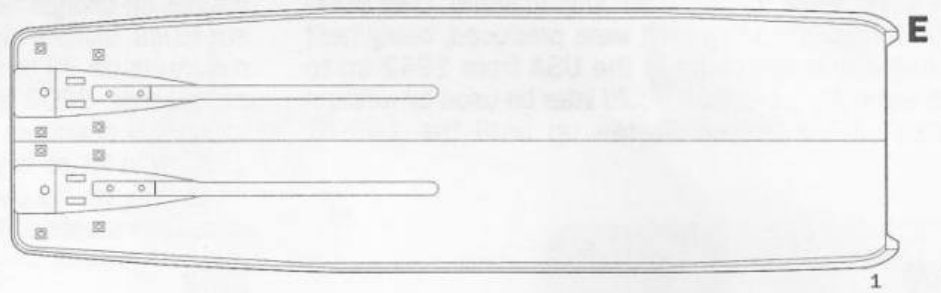
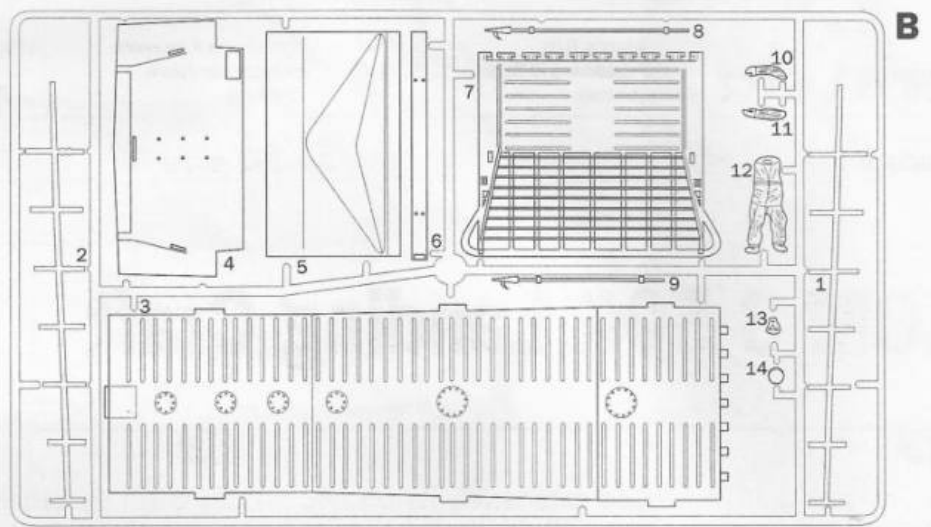
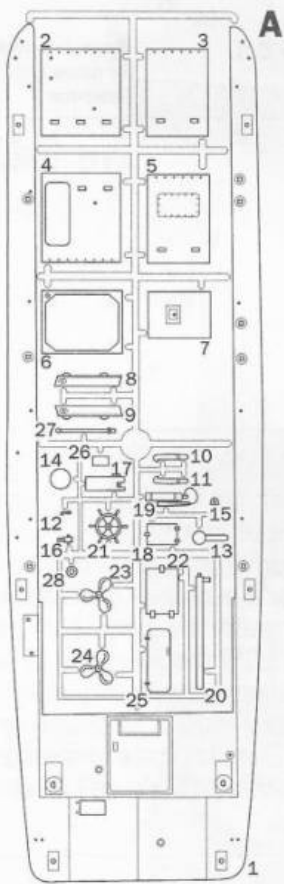
Dit landingsvaartuig werd in de Tweede Wereldoorlog veel gebruikt door de Amerikaanse en Engelse marine's voor het transport van de vrachtschepen naar de stranden van voertuigen op wielen, lichte gepantserde middelen en materialen tot een maximaal gewicht van 30 ton. Van de LCM model 3 werden van 1942 tot het einde van de oorlog meer dan 8000 exemplaren gebouwd bij talrijke scheepswerven van de Verenigde Staten. In de daarop volgende jaren werd dit schip door de westerse bondgenoten van Amerika tot de jaren 80 gebruikt.

D

Dieses Landefahrzeug wurde im Zweiten Weltkrieg eingehend von der amerikanischen und der englischen Marine für den Transport der Kampffahrzeuge, leichten Panzerwagen und Materialien mit einem Höchstgewicht bis zu 30 Tonnen von den Frachtschiffen zu den Stränden eingesetzt. Von dem LCM Modell 3 wurden über 8.000 Exemplare produziert, die seit dem Jahr 1942 bis zum Ende des zweiten Weltkriegs in zahlreichen Werften der Vereinigten Staaten gebaut wurden. In den darauffolgenden Jahren bis in die 80' Jahre verwendeten die westlichen Alliierten Amerikas dieses Wasserfahrzeug.

E

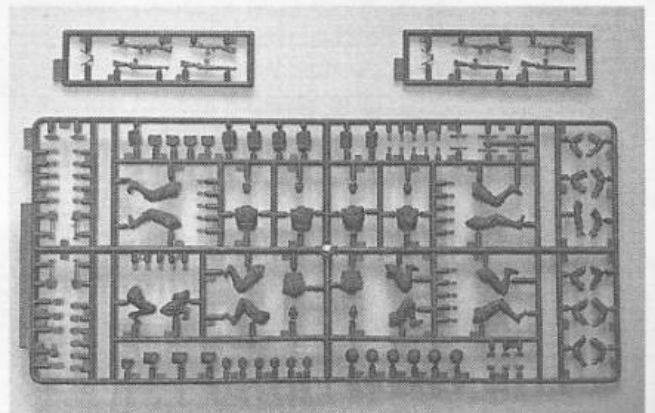
Esta nave de desembarco fue extensamente empleada por las marinas americana e inglesa durante la Segunda Guerra Mundial para el transporte de vehículos con ruedas, carros armados ligeros y materiales (con un paso de hasta 30 ton.) desde los barcos a la playa. Más de 8000 LCM modelo 3 fueron producidos, que se construyeron desde 1942 hasta el final de la guerra en numerosos astilleros de los Estados Unidos. Posteriormente se emplearon por los aliados occidentales de los Estados Unidos hasta los años 80s.



0.8 Canvas Rope



0.3 Gray Cable



I numeri si riferiscono all'assortimento colori ITALERI MODEL MASTER/ Acryl Paint System.

The indicated colours number refer to the ITALERI MODEL MASTER/ Acryl Paint System

Die angegebenen Farbzahlen beziehen sich auf die ITALERI MODEL MASTER/ Acryl Paint System

Figures and accessories

I numeri si riferiscono all'assortimento colori ITALERI MODEL MASTER R/Acryl Paint System

The indicated colours number refer to the ITALERI MODEL MASTER R/Acryl Paint System

Die angegebenen farbnummern beziehen sich auf die ITALERI MODEL MASTER R/Acryl Paint System

Les références indiquées concernent les peintures ITALERI MODEL MASTER R/Acryl Paint System

Figures and accessories

A

Bright Brass

MODEL MASTER - 1782
MODEL MASTER ACRYL - 4672

B

Medium Gray

MODEL MASTER - 1721
MODEL MASTER ACRYL - 4746

C

Gun Metal

MODEL MASTER - 1405
MODEL MASTER ACRYL - 4681

D

Olive Drab

MODEL MASTER - 1711
MODEL MASTER ACRYL - 4728

E

Flat White

MODEL MASTER - 1768
MODEL MASTER ACRYL - 4769

F

Red

MODEL MASTER - 1550
MODEL MASTER ACRYL - 4714

G

Skin Tone

MODEL MASTER - 1516
MODEL MASTER ACRYL - 4390

H

Field Drab

MODEL MASTER - 1702
MODEL MASTER ACRYL - 4708

I

Black (Flat)

MODEL MASTER - 1749
MODEL MASTER ACRYL - 4768

J

Field Green

MODEL MASTER - 1712
MODEL MASTER ACRYL - 4739

K

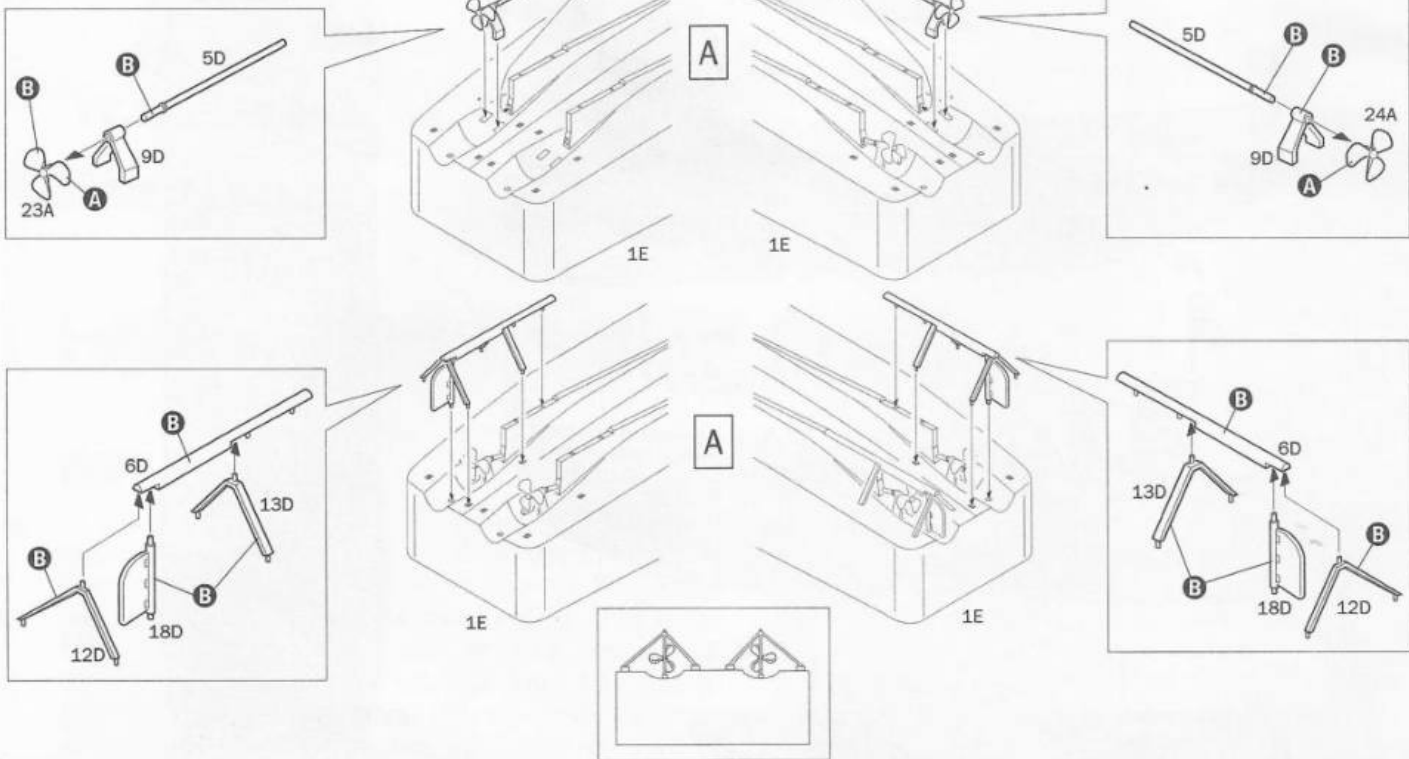
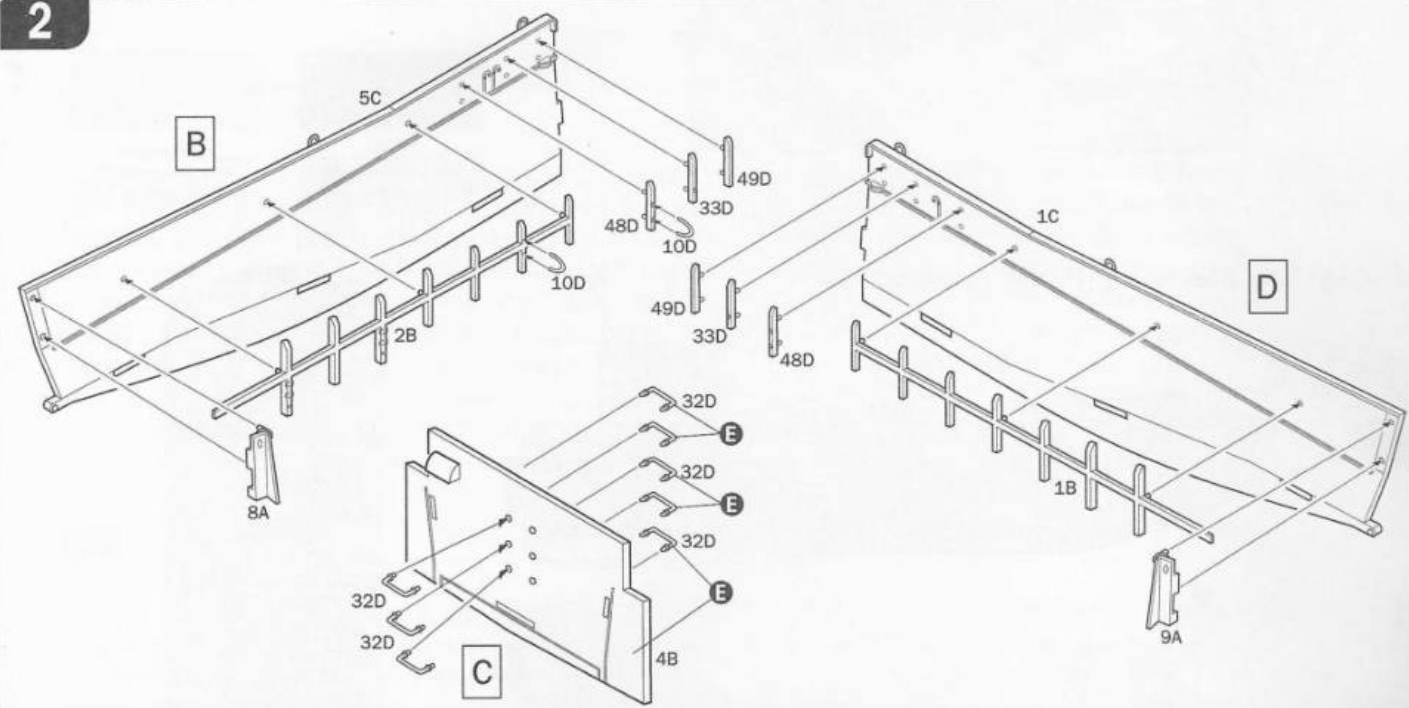
Wood

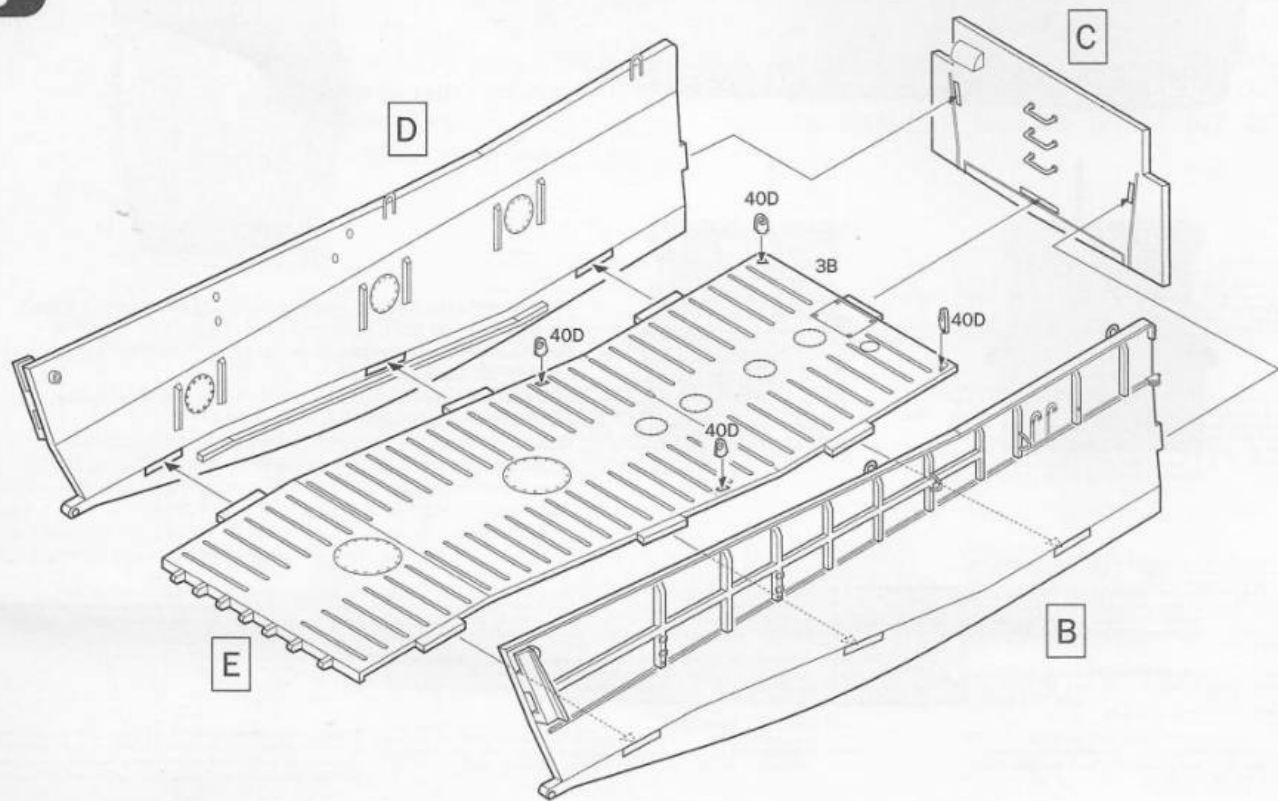
MODEL MASTER - 1735
MODEL MASTER ACRYL - 4673

L

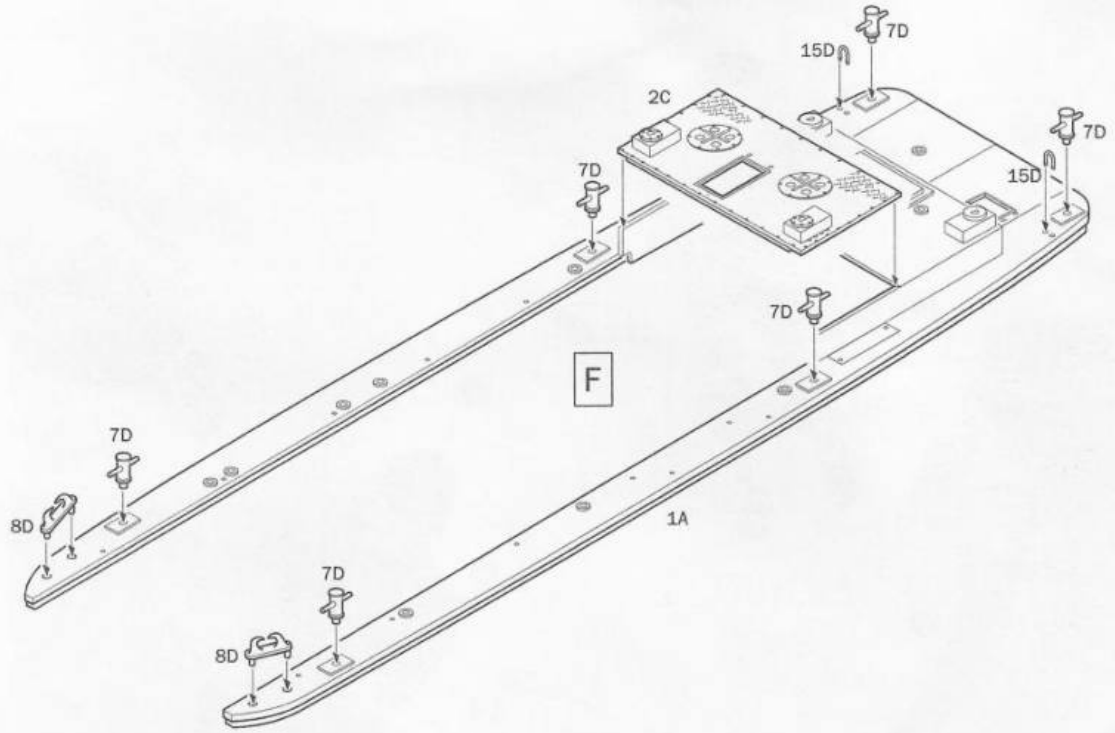
Panzer DunkelGelb

MODEL MASTER II - 2095
MODEL MASTER ACRYL - 4796

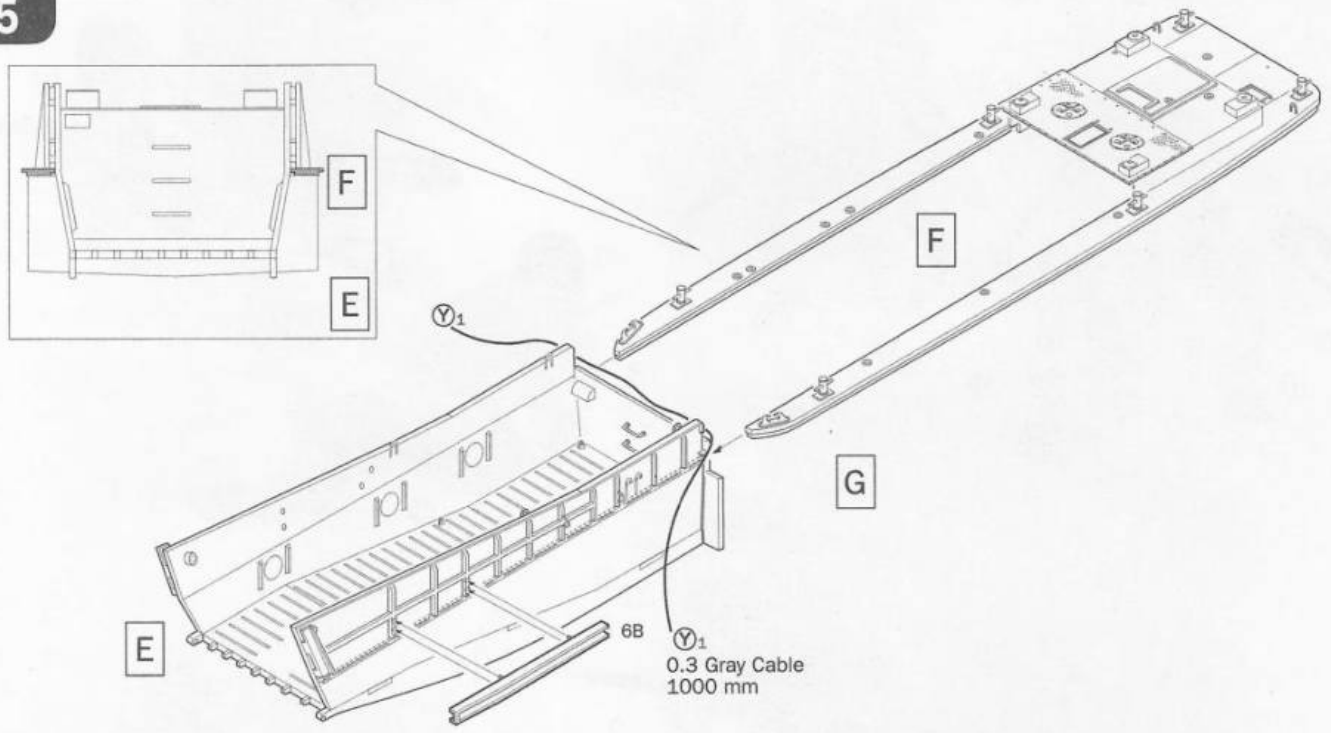
1**2**

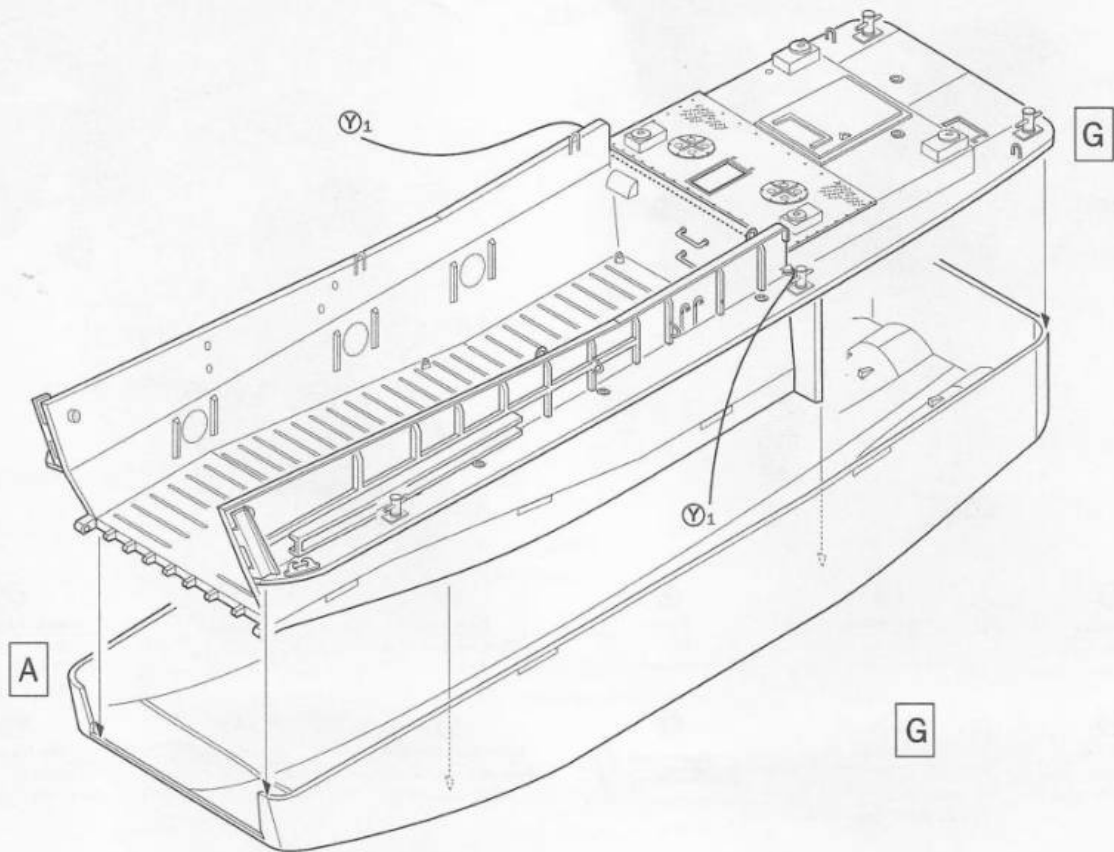
3

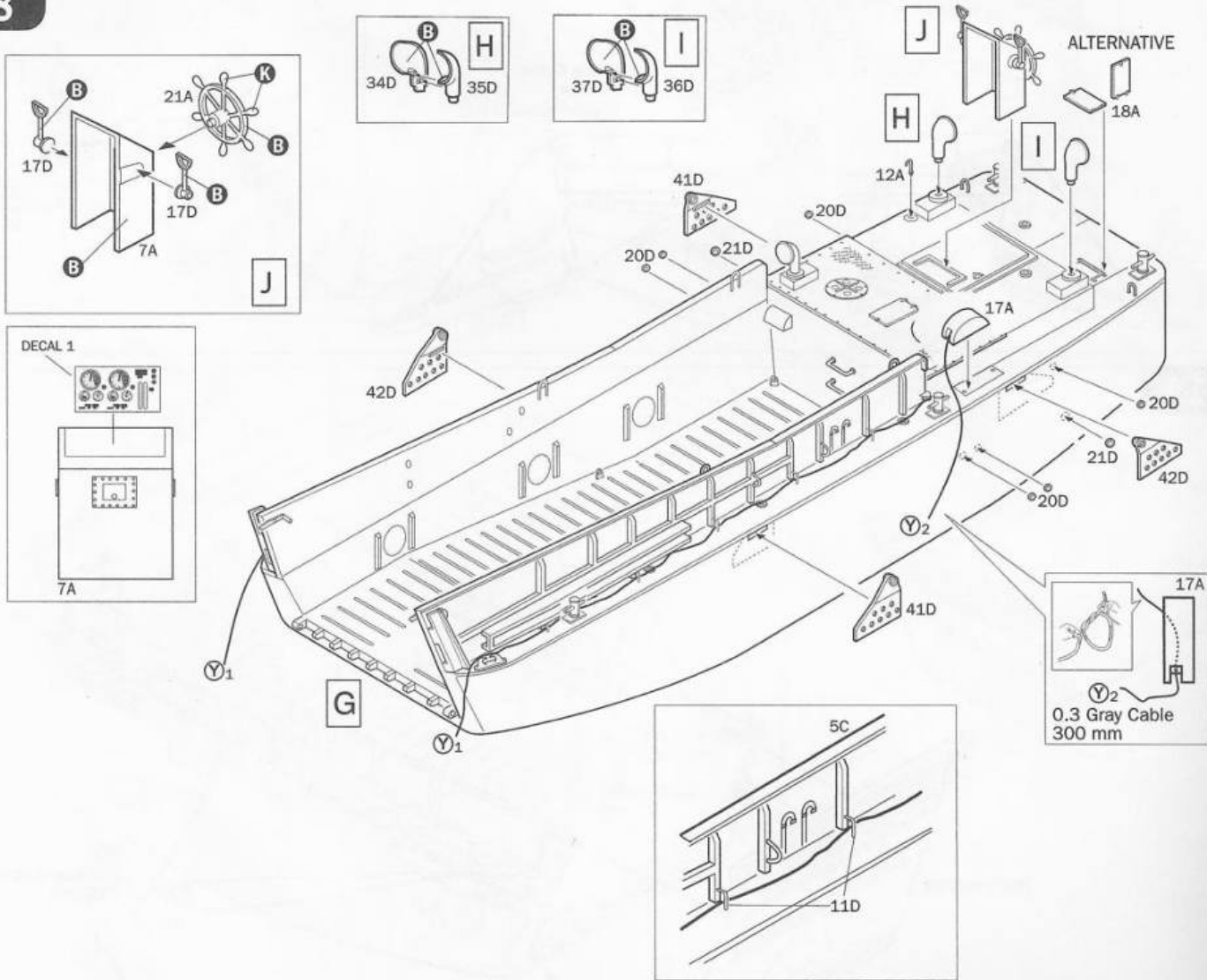
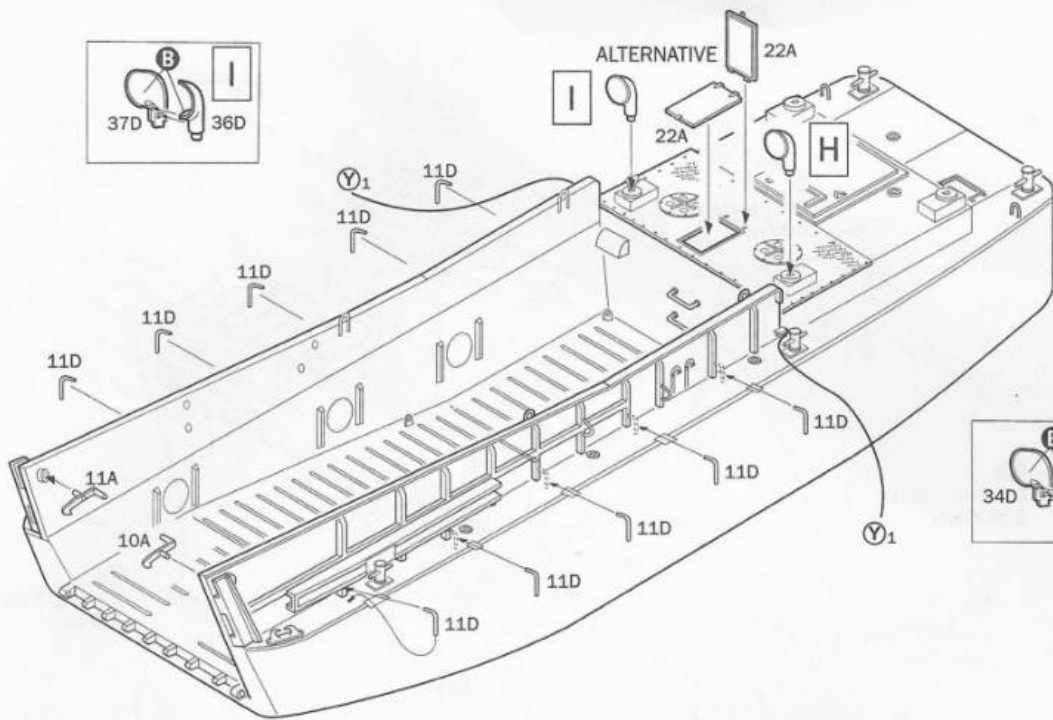
4

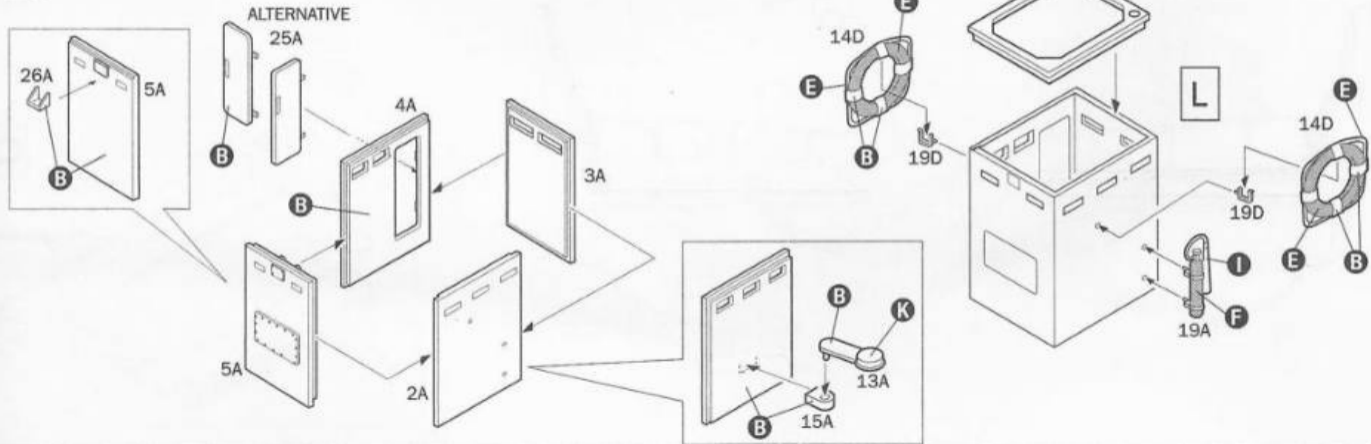


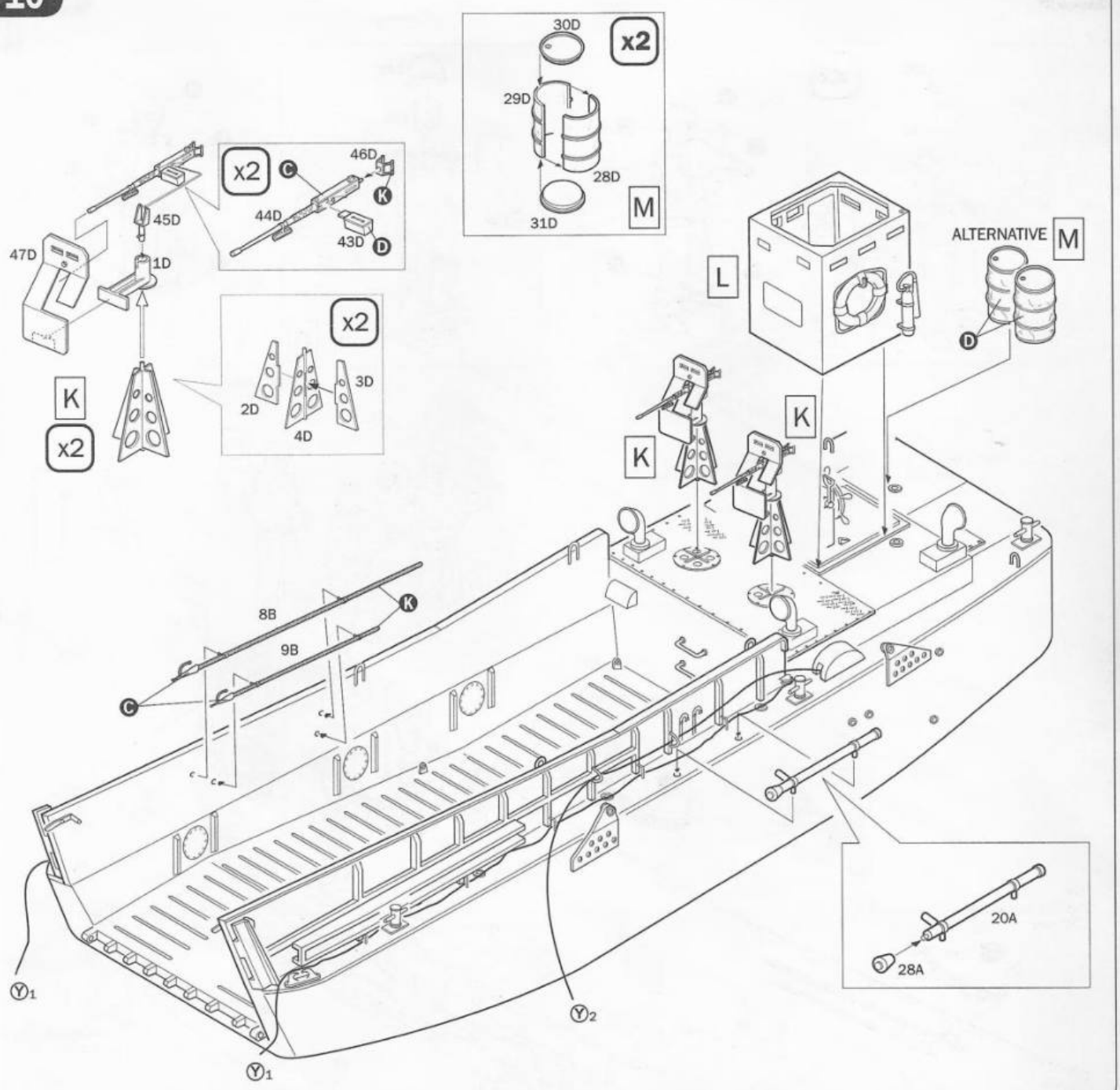
5

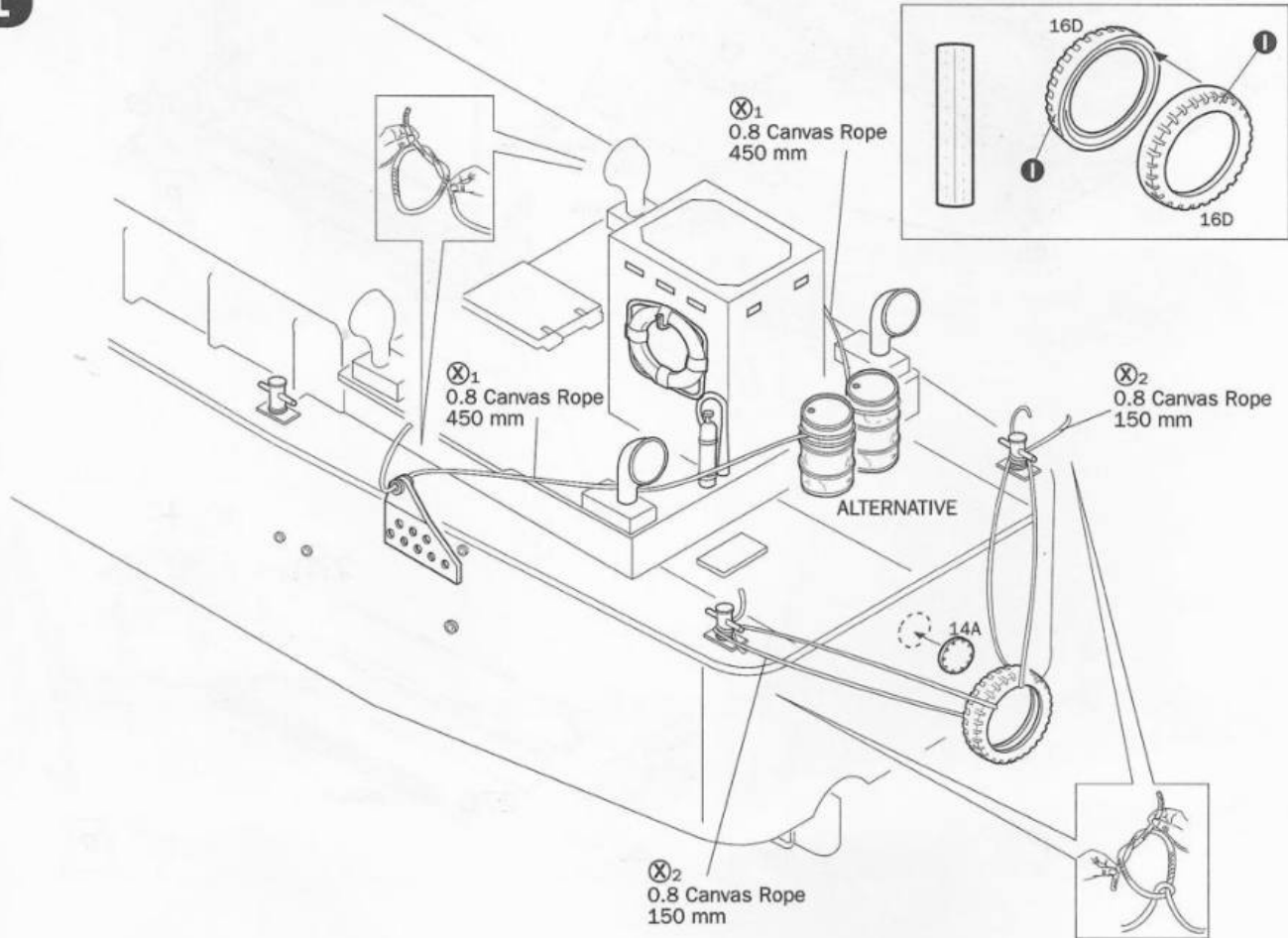


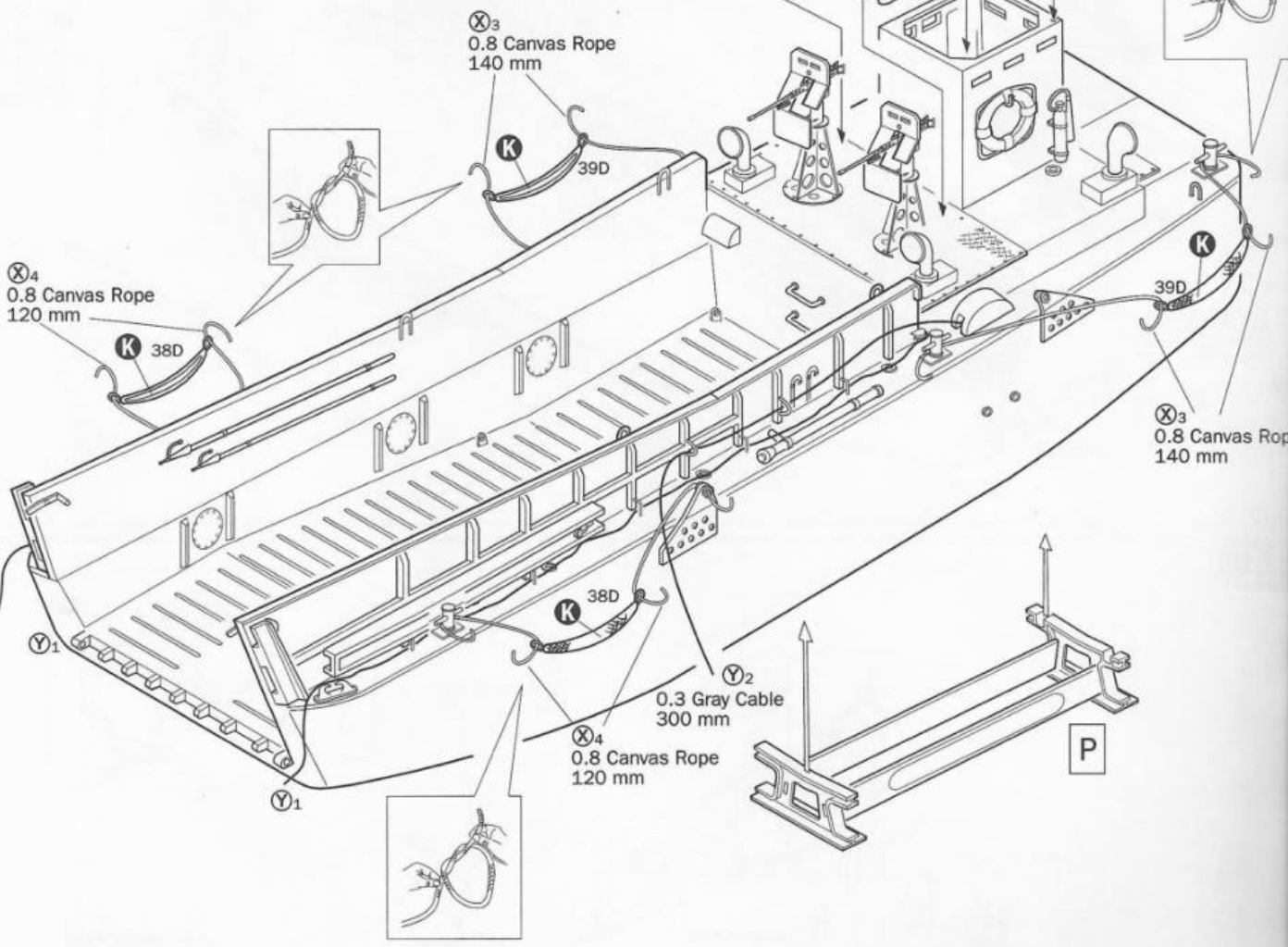
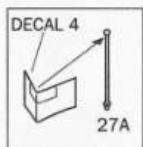
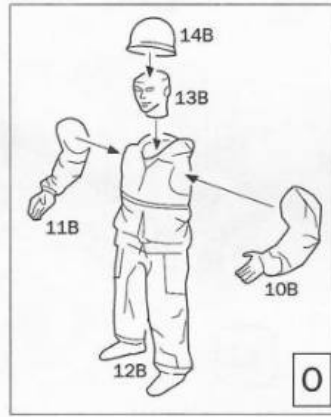
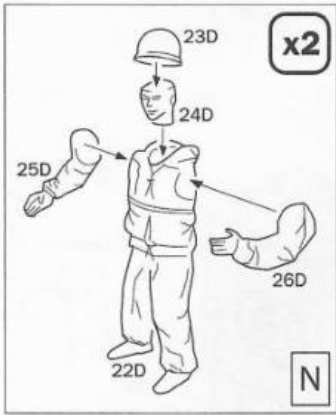


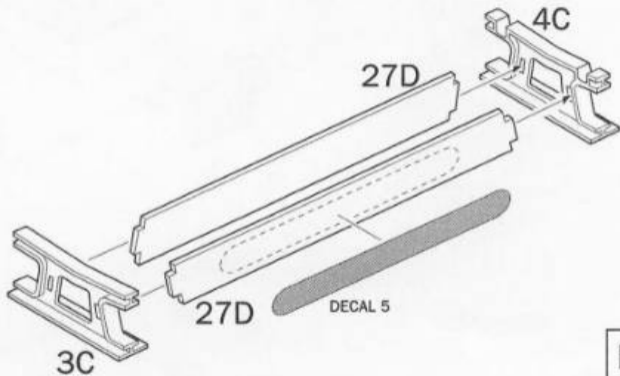


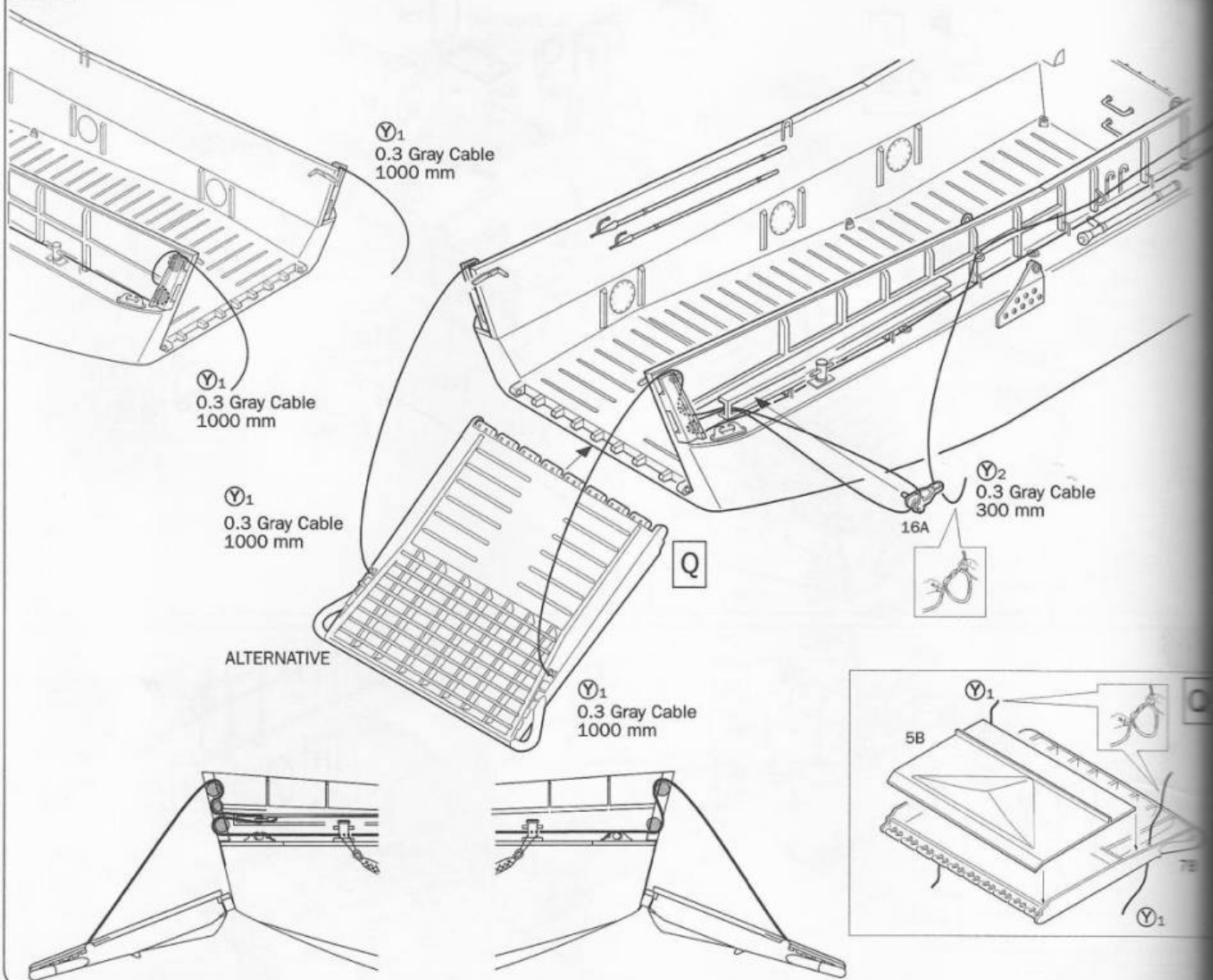












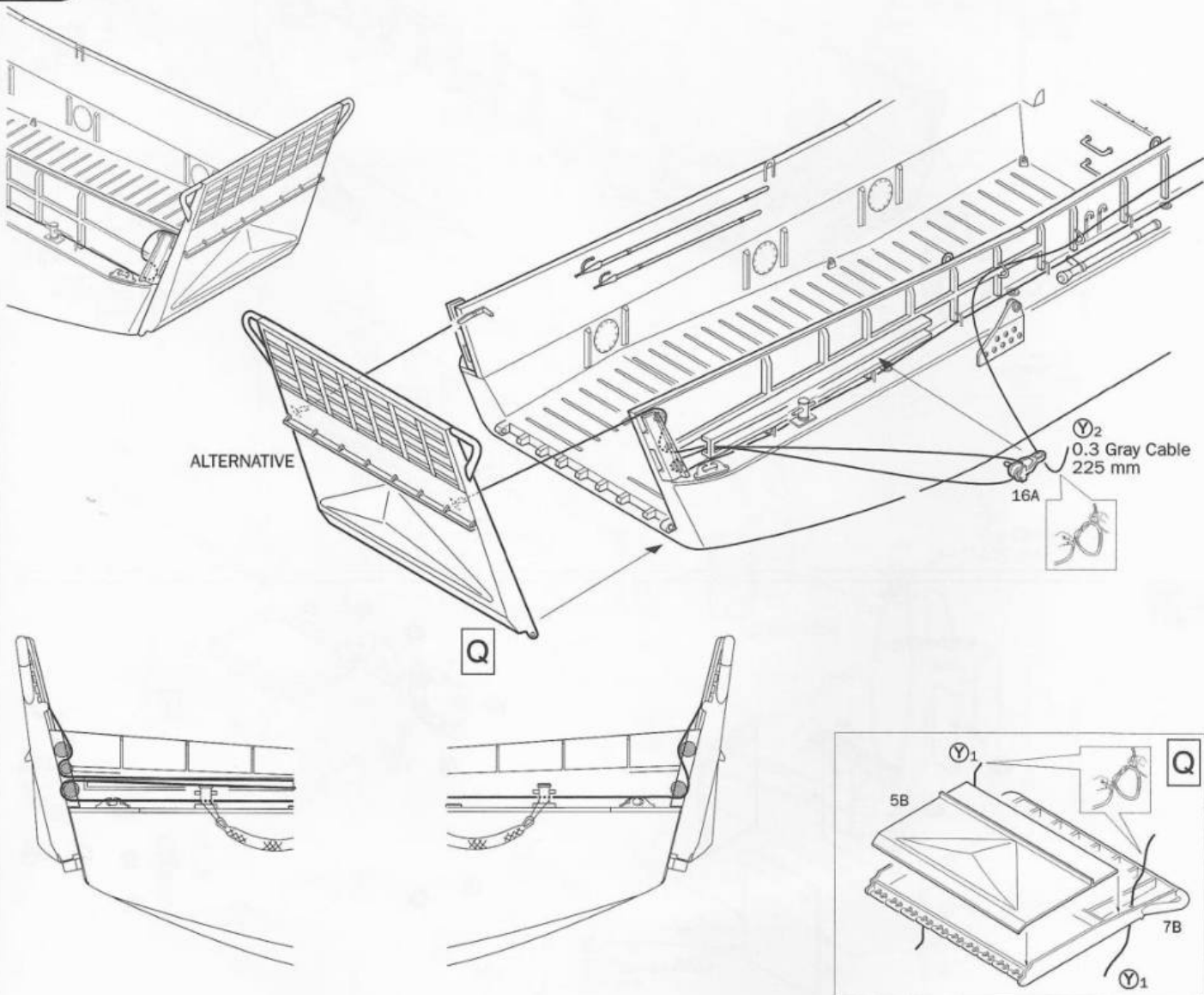




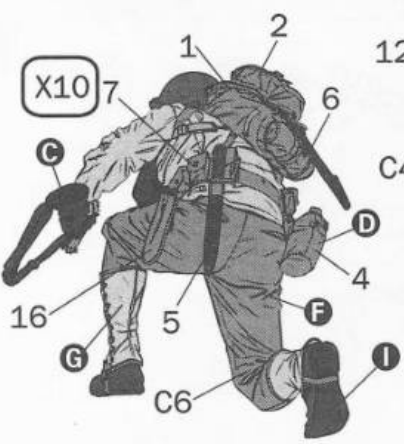
FIGURE 1



FIGURE 2



X3



X10

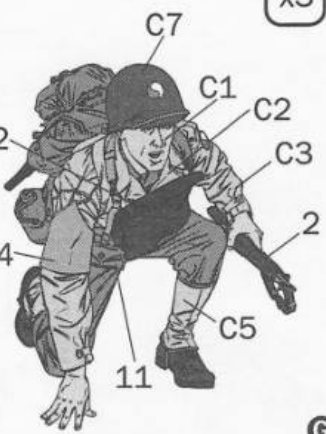
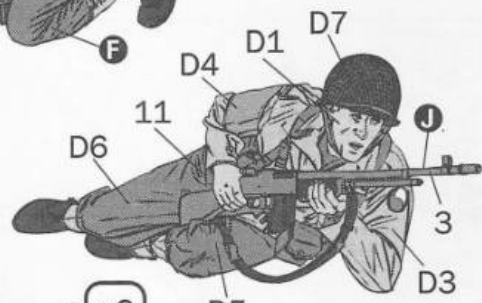
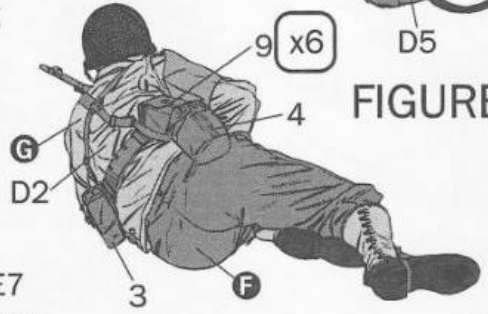


FIGURE 3



X6

FIGURE 4



X6



FIGURE 5



X10



FIGURE 6



X10

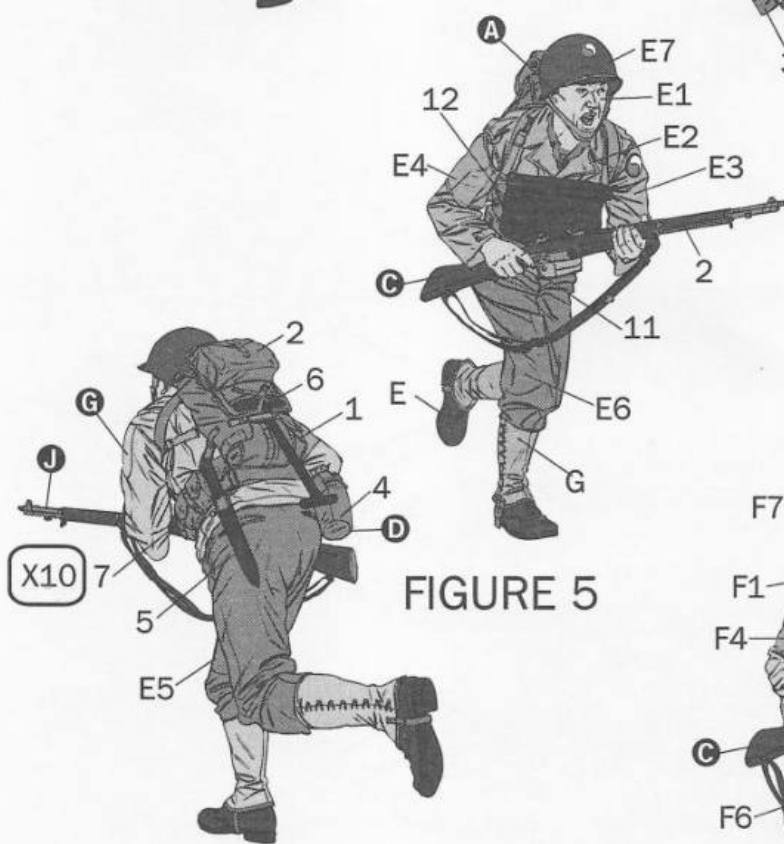


FIGURE 5

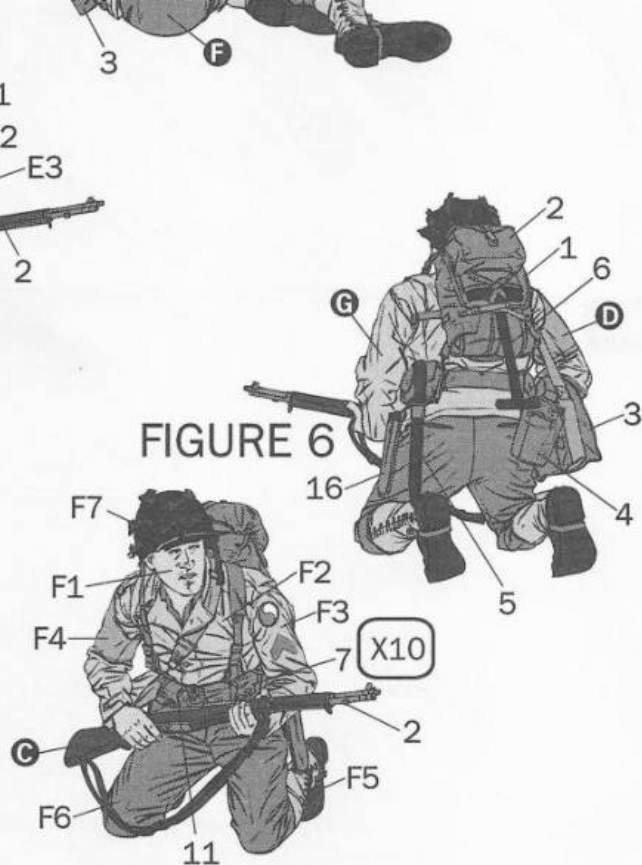


FIGURE 6

A

Skin Tone

MODEL MASTER - 1516
MODEL MASTER ACRYL- 4390

B

Gunship Gray

MODEL MASTER - 1723
MODEL MASTER ACRYL- 4752

C

Wood

MODEL MASTER - 1735
MODEL MASTER ACRYL- 4673

D

Field Green

MODEL MASTER - 1712
MODEL MASTER ACRYL- 4739

E

Leather

MODEL MASTER - 1736
MODEL MASTER ACRYL- 4674

F

Panzer DunkelGelb

MODEL MASTER II - 2095
MODEL MASTER ACRYL- 4796

G

Dark Tan

MODEL MASTER - 1742
MODEL MASTER ACRYL- 4709

H

Field Drab

MODEL MASTER - 1702
MODEL MASTER ACRYL- 4708

I

Black (Flat)

MODEL MASTER - 1749
MODEL MASTER ACRYL- 4768

J

Gun Metal (Metalizer)

MODEL MASTER - 1405
MODEL MASTER ACRYL- 4681

K

Flat White

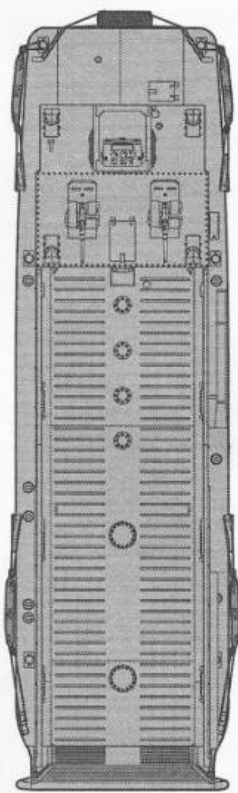
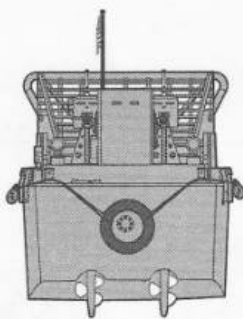
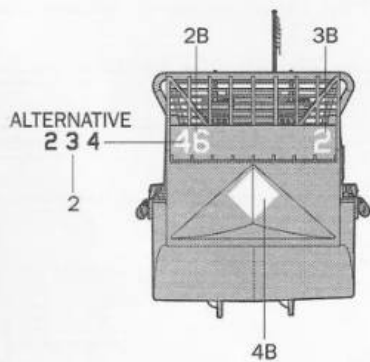
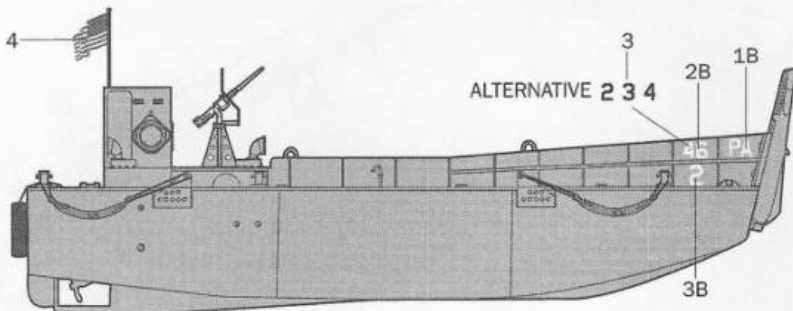
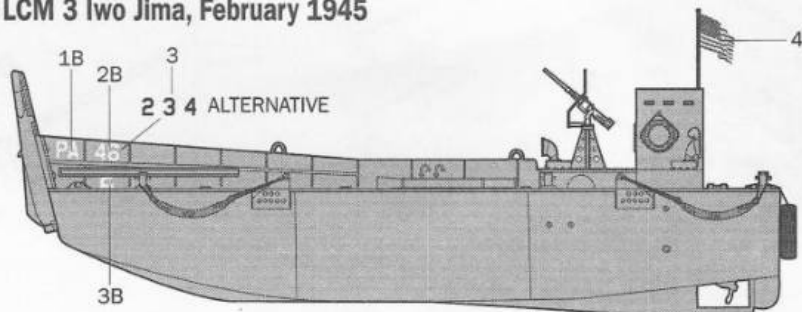
MODEL MASTER - 1768
MODEL MASTER ACRYL- 4769

L

Flat Light Blue

MODEL MASTER - 1508
MODEL MASTER ACRYL- 4659

U.S. Navy - LCM 3 Iwo Jima, February 1945

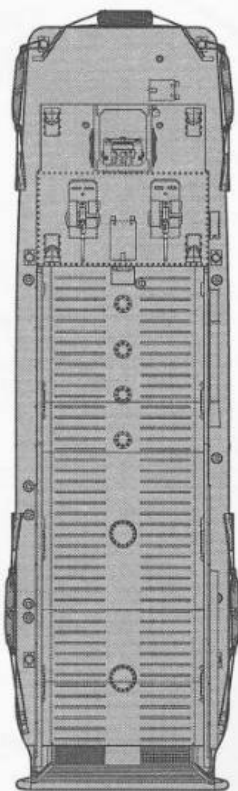
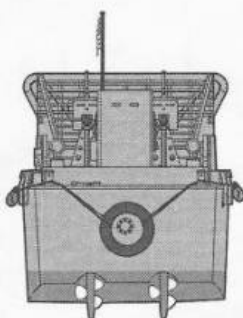
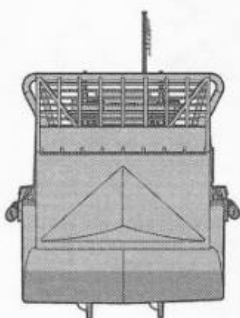
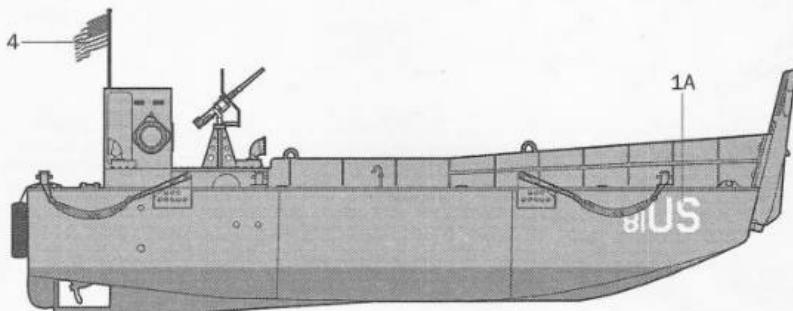
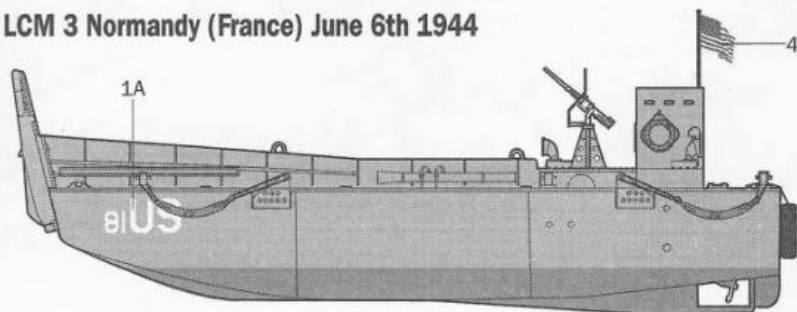


Red
 MODEL MASTER - 1550
 MODEL MASTER ACRYL - 4714



Medium Gray
 MODEL MASTER - 1721
 MODEL MASTER ACRYL - 4746

U.S. Navy - LCM 3 Normandy (France) June 6th 1944



For a perfect application of the decals, we suggest using **MODEL MASTER** products 2145 or 2146.

Per una perfetta applicazione delle decals, si consiglia l'uso dei prodotti **MODEL MASTER** 2145 oppure 2146.

Für eine perfekte anbringung der decals wird die verwendung von **MODEL MASTER** no. 2145 oder 2146 empfohlen.

Pour une pose parfaite des decals, nous vous recommandons l'utilisation des produits à decals **MODEL MASTER** réf. 2145 ou 2146.

Voor het perfect aanbrengen van transfers, adviseren wij gebruik te maken van de **MODEL MASTER** producten 2145 of 2146.

Para facilitar la colocación de las calcomanías aconsejamos un resultado por