

# GERMAN HORCH 1a with 2cm FLAK38

## 1/35 MILITARY MINIATURE SERIES



The Horch 1a was a standard heavy passenger or personnel carrier of the Wehrmacht and had resulted from the programme instituted in the mid 1930s to provide the Wehrmacht with a range of vehicles on a standardised type of chassis. The 'heavy' category was reserved for cars of 3000cc engine capacity or over. Horch/Auto-Union were main builders in Germany of cars in this category, and the production period of the Horch 1a was 1937-40, though the vehicles remained in service throughout WW2. Vehicles of this type on the standardised (Einheits) chassis were intended to replace cars of similar type which had been built on commercial chassis. The actual production period of the Einheits (standard) chassis car was relatively short because in the 1941-42 period the Schell-Programm was introduced which was an attempt to rationalise production, build simpler less sophisticated vehicles, and reduce the number of different models on the ordnance inventory. The heavy car Einheits chassis was phased out under the Schell-Programm and the heavy car type body was then mounted on the standard light truck chassis, though the cars then produced looked externally quite similar to the earlier Einheits vehicles. The heavy car chassis as made by Horch was superbly engineered. A striking feature was the steerable rear axle which made the vehicle very manoeuvrable, though also complicated. In the otherwise similar Horch 1b of 1940, this feature was dropped in favour of a conventional rear axle. The personnel carrier (Kübel) body was in pressed metal with spare wheel recesses and detachable doors. The V8 Auto-Union/Horch 108 engine was of 3823 cc capacity and gave 81 bhp at 3600 rpm. The wheelbase was 3000 mm and the weight 3150 kg. The gearbox gave five forward speeds and reverse. In the Wehrmacht's ordnance inventory the Horch 1a was known as the 'Protzkraftwagen (Kfz 69) mit Einheitsfahrgestell II für schwerer Pkw'. This translated as 'Towing vehicle (type 69) with standardised chassis II for the heavy passenger car'. Vehicles used as AA unit cars were designated Kfz 81 rather than Kfz 69. The 2 cm Flak 38 was a standard anti-aircraft gun of the Wehrmacht and was used by Army, Waffen-SS, and Luftwaffe AA units. The Flak 38 in 1940, though the earlier model was still to be seen in service throughout the war. Improvements in the 2 cm Flak 38 in 1940, though the

earlier model was still to be seen in service throughout the war. Improvements in the 2 cm Flak 38 included the addition of a shield, lighter weight, and better portability. The normal detachment for each gun was six men. It could be broken into six loads for man-packing or horse-packing over difficult terrain. For action the gun was emplaced on the ground but could be fired from its two-wheel trailer carriage in an emergency. Barrel recoil and residual gas pressure operated the automatic breech and firing action. The gun actually had a multirole; AA, anti-tank, and anti-personnel. The Flak 38 in firing order weighed 924 lbs, was 157 inches long overall, had an emplaced height of 30 inches, a rate of fire of 220-450 rounds per minute, a maximum horizontal range of 5,246 yards, and a maximum vertical range of 4,012 yards. Elevation limits were -10 to +90 degrees. Ammunition came in HE (high explosive) and AP (armour piercing) forms and was loaded in 20 round magazines. Typical deployment for the Flak 38 and its Kfz 69/Kfz 81 towing vehicle was in infantry units, the gun being used mainly for anti-aircraft defence in the field, though it was just as frequently used against ground targets when appropriate. In the 1939-41 style organisation of the German Army, one platoon of the anti-tank company in an infantry battalion had one of its platoons equipped with 2 cm Flak 38 in place of its four 3.7 cm Pak 35/36 anti-tank guns. In addition to this one company of the divisional anti-tank gun battalion was almost invariably equipped with 2 cm Flak 38 guns in one of its companies. There were usually three platoons each with four 2 cm guns and one MG 34 or MG42 machine gun on an AA mount throughout the war. In some divisions, also, the third platoon of the infantry gun company had two 2 cm Flak 38s in one of its sub-sections, the other two sub-sections retaining their two 15 cm IG 33 infantry howitzers. The 2 cm Flak 38 was in wide use by the Luftwaffe in their own Flak companies defending airfields and other installations.

Mitte 1930 stellte die deutsche Wehrmacht ein Programm auf, die Truppen mit einer Reihe von standardisierten Fahrzeugen auszustatten. Automobile mit über 3 Liter Hubraum wurden als "SCHWERE" Typen bezeichnet, auch der Horch 1a. Die Horch-Auto-Union stellte diesen PKW

von 1937 - 1940 her und das Fahrzeug konnte bis Ende des Krieges auf allen Plätzen gesehen werden. Lang war die Produktionszeit zwar nicht, denn bereits ab 1941/42 lief das "Schell" Programm (Einheitsfahrzeuge) das dazu diente, das Fahrzeugwesen zu vereinfachen und rationalisieren. Die schwere Karosserie wurde nunmehr auf das Fahrgestell des leichten Einheits-Lkw montiert, das Aussehen jedoch blieb fast gleich. Technisch hervorragend war das Fahrgestell von Horch, auffallend die lenkbare Hinterachse, die das Fahrzeug in allen Lagen bestens manövrierbar machte.

Ähnlich war der Horch 1b von 1940, jedoch mit der normalen Hinterachse. Der Kübelaufbau wurde aus Metall gepresst, die Ersatzräder wurden in seitlichen Nischen untergebracht und die Türen waren abnehmbar. Der V8 Motor von Auto-Union-Horch hatte 3,823 l mit 31 PS bei 3600 RPM. Der Radstand 3000 mm, Gewicht 3150 Kilo, 5 Vorwärtsgänge. Im Wehrmacht Feldzeugwesen war der Horch 1a bekannt als Protzkraftwagen Kfz. 69 mit Einheitsfahrgestell II für schwere Pkw's, kurzer Name : Kfz. 69. Dieses Fahrzeug war auch als Luftschutzwagen im Einsatz als Kfz. 81 mit der 2 cm Flak 38. Die 2 cm Flak 38 von 1940.

Bei der Flak von 1940 gab es verschiedene Verbesserungen, z.B. das Schild, leichteres Gewicht und bessere Transportmöglichkeiten. Normale Bedienung waren 6 Mann. Die Flak konnte daher auch jetzt in 6 Traglasten für Mannschafts-transport oder Munitlast zerlegt werden, Ideal für schwieriges Gelände. Im Einsatz wurde die Kanone meistens abgeprotzt, es konnte aber auch vom Fahrgestell aus bedient werden. Rohrrücklauf mit Rückstossgasdruck wirkte auf Verschluss und Abfeuerung. Das Geschütz konnte in der Luftabwehr, der Panzerabwehr und im Infanterieangriff eingesetzt werden.

Gewicht feuerbereit 419 Kilo, 4 m lang, Höhe 76 cm, Schussleistung 220 - 450 Schuss/Minute. Max. Schussweite 4.800 Meter und Schusshöhe 3.670 Meter. Schwenkbar von -10 bis +90 Grad. Munition (Hochexplosiv oder Panzerbrechend) in Magazinen a 20 Schuss.

Einsatz bei der Infanterie als Luftabwehrkanone, jedoch Haupteinsatz bei der Luftwaffe als Flak auf Feldflugplätzen und anderen, wichtigen Objekten.



Please read this before commencing assembly

- ★ Study the instructions and photographs before commencing assembly.
- ★ You will need a sharp knife, a pair of pliers, a file and a pair of tweezers.

☛ This mark shows the colour.

★ Vor Beginn die Bauanleitung Studieren und den Nummern nach die Elemente zusammenbauen.

★ Kleine Teile hält man mit Pinzette fest.

☛ Zeichen für Bemalung.

<<Parts for Horch 1 a>>  
<<Teile für Horch 1a>>

**A Parts**

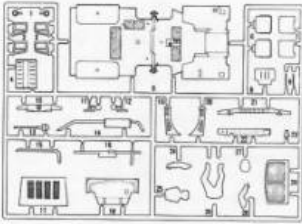

**B Parts**

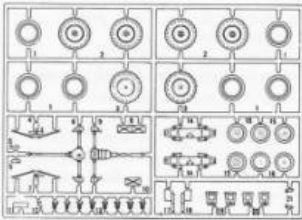

**C Parts** Unnecessary: 5,9,10,15,21,23  
Diese Teile werden nicht benötigt: 5,9,10,15,21,23

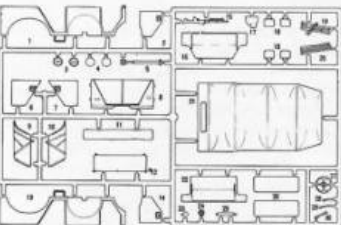

**Z Parts**

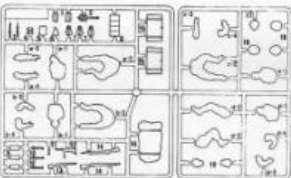

**1 Lower Parts**  
**Unterteile**

<<B5 Part>>  
<<Haken B5>>

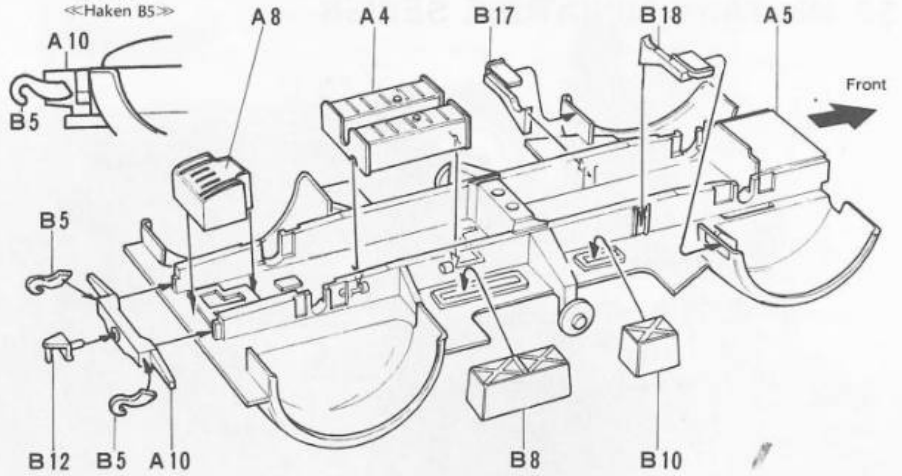

**2 Differentials**  
**Differentialgetriebe**

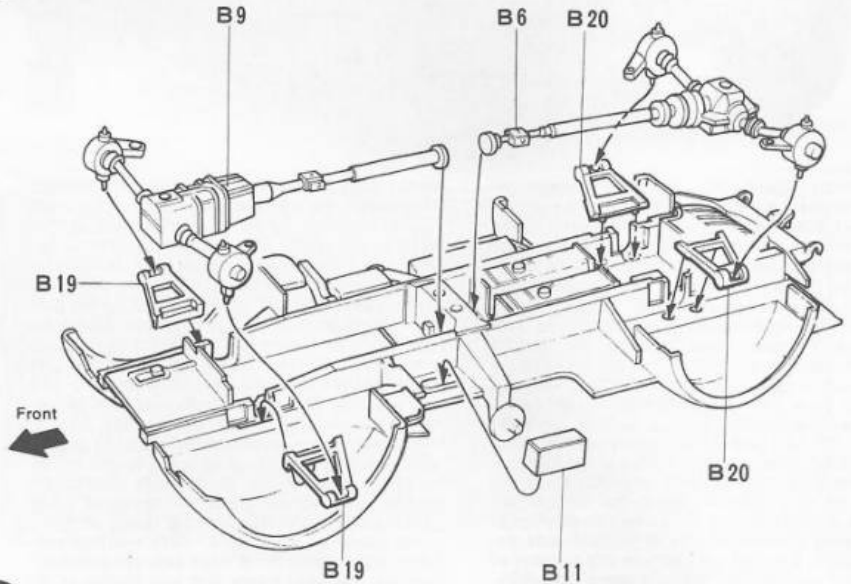

**3 Tie Rod**  
**Spurstangen**

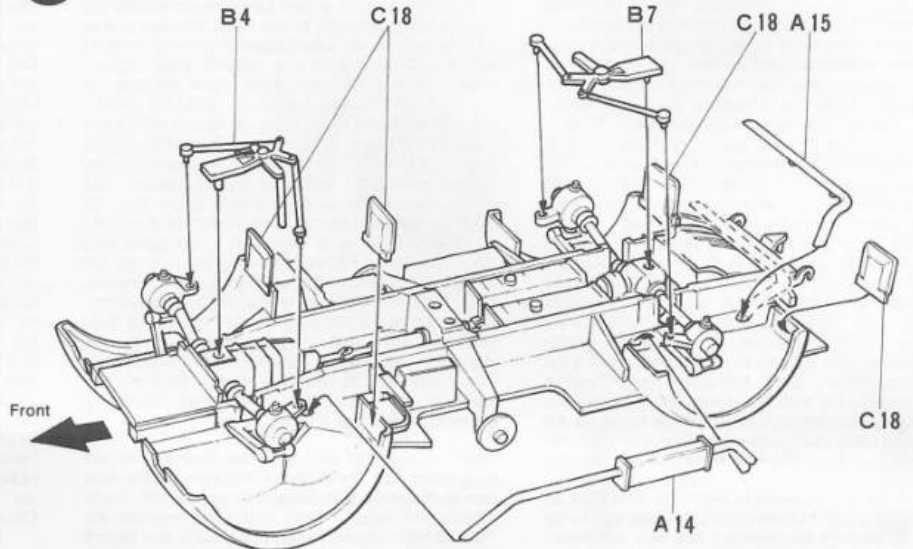

**4** <<Wheels>>  
<<Räder>>

When A and Wheel B can be distinguished from each other by the number of center bolts.  
Die Räder unterscheiden sich wie unten gezeigt.



Wheel A  
Rad A



Wheel B  
Rad B

**5** <<Lower Arm>>  
<<Achsarm>>

B13: note the direction.  
B13: Auf die Richtung achten

**6** <<Fixing of Wheels>>  
<<Räder Einbau>>

Fix lower arms carefully to chassis  
Achsarme sorgfältig einbauen

↑ Front

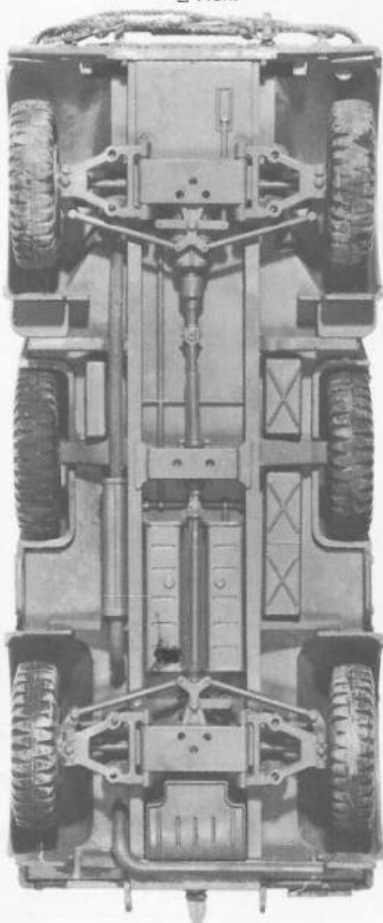

**4** Wheels  
Räder

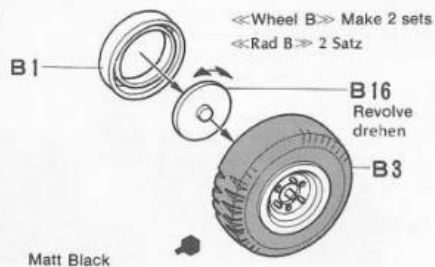
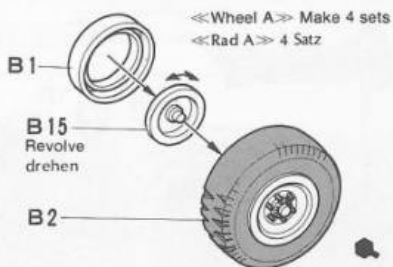

Matt Black

**5** Lower Arm  
Achsarm

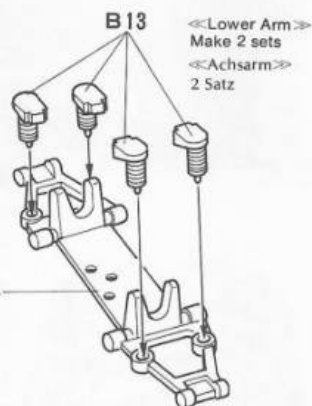
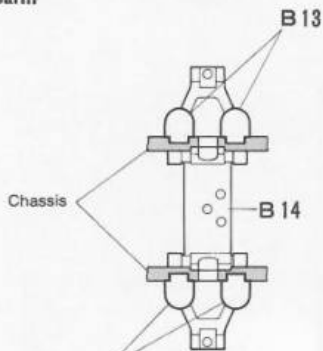

**6** Fixing of Wheels  
Räder Einbau

<<Fixing of Lower Arm>>  
<<Achsarm Einbau>>

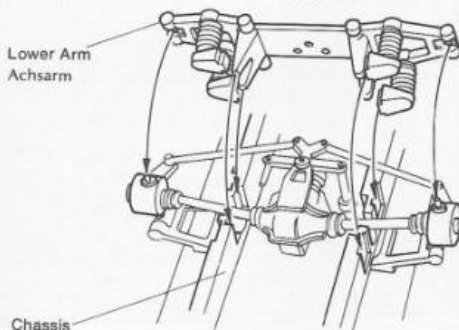

<<Cross Sectional View>>  
<<Querschnitt>>

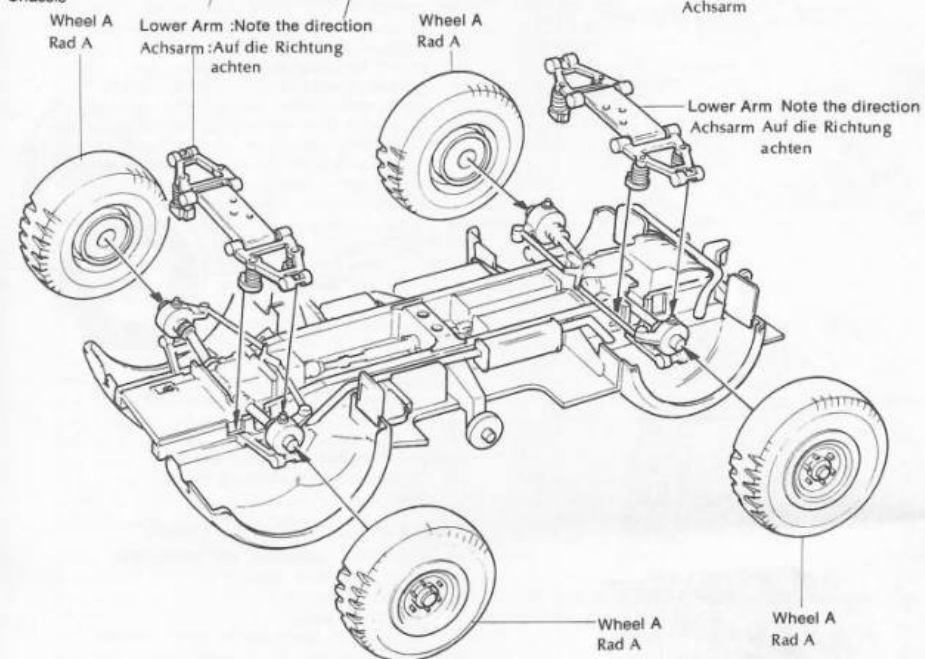
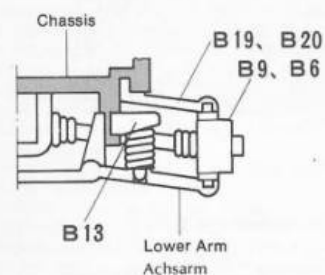

**7** <<Engine Hood>>  
<<Motorhaube>>

Gate (connection between parts and runner) should be cut off very carefully

Die Teile vorsichtig vom Spritzling abtrennen

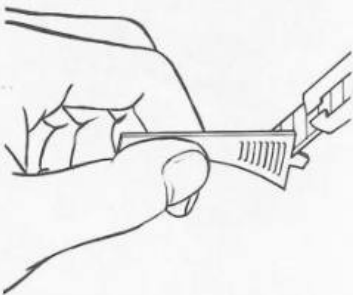

**7** Engine Hood  
Motorhaube

<<Engine Hood>>  
<<Motorhaube>>

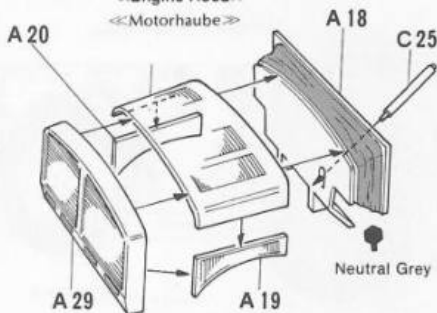

<<Chassis>>

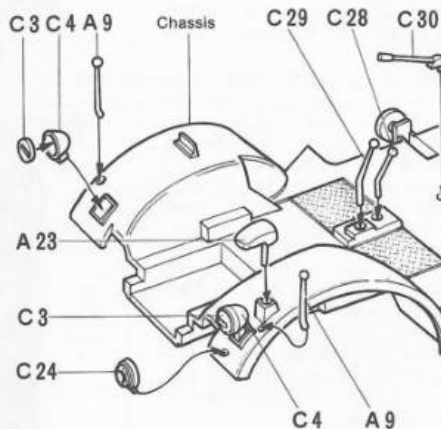

**8** Body  
Karosserie

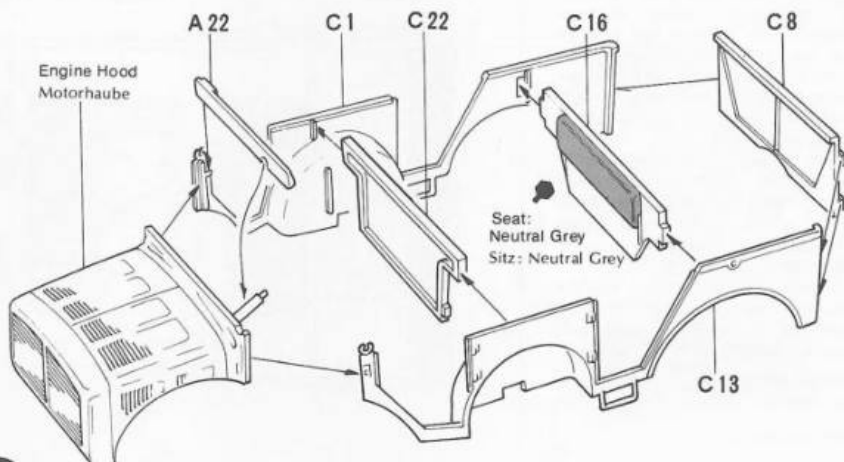
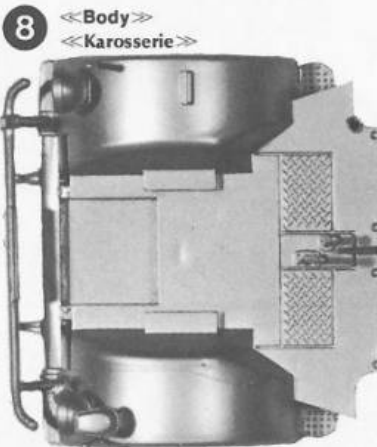

**9** Fixing of Body  
Karosserie Einbau

Fix body first  
Erst Karosserie einbauen

**9** <<Fixing of Body>>  
<<Karosserie Einbau>>

Spare wheels and bumper should be fixed after the body is fixed to chassis

Erst Karosserie, dann Ersatz-Räder und Stosstange einbauen

<<Bumper>>  
<<Stosstange>>

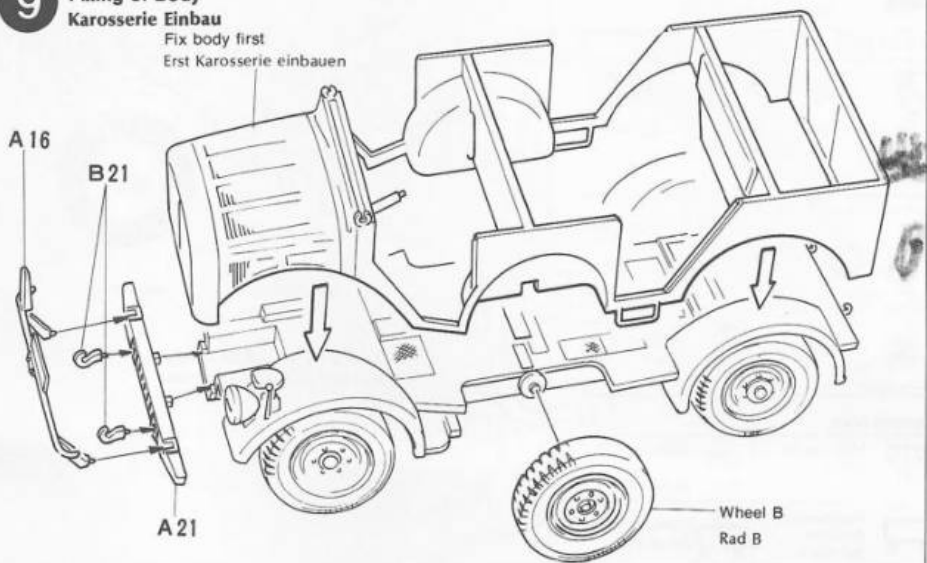

# 11 Construction and Painting of Figures

## «Männchenbau»

Figures should be mounted on the body after being constructed and painted. They wear a camouflage suit of the German army. The helmets are also covered with camouflage cloth. Die Figuren je nach Wunsch bemalen



### «Accessory Parts»

### «Zubehör»

- «Wooden Box» x2
- «Holzkisten» (x2)

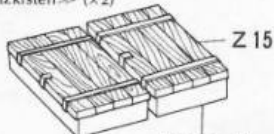

- «Grenade» x3 (Matt Earth)
- «Handgranaten» x3
- «Ammunition Box» (Munitionskästen)



- «Tarpaulin»
- «Planen»
- «Gas Mask Cover» x3
- «Gasmasken» x3

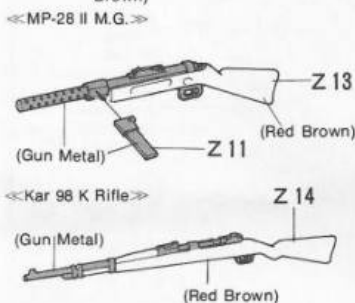
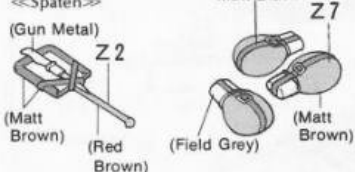

# 10 Body Parts

## Karosserie Teile

«Front Seat» Make 2 sets  
 «Front Sitz» 2 Satz

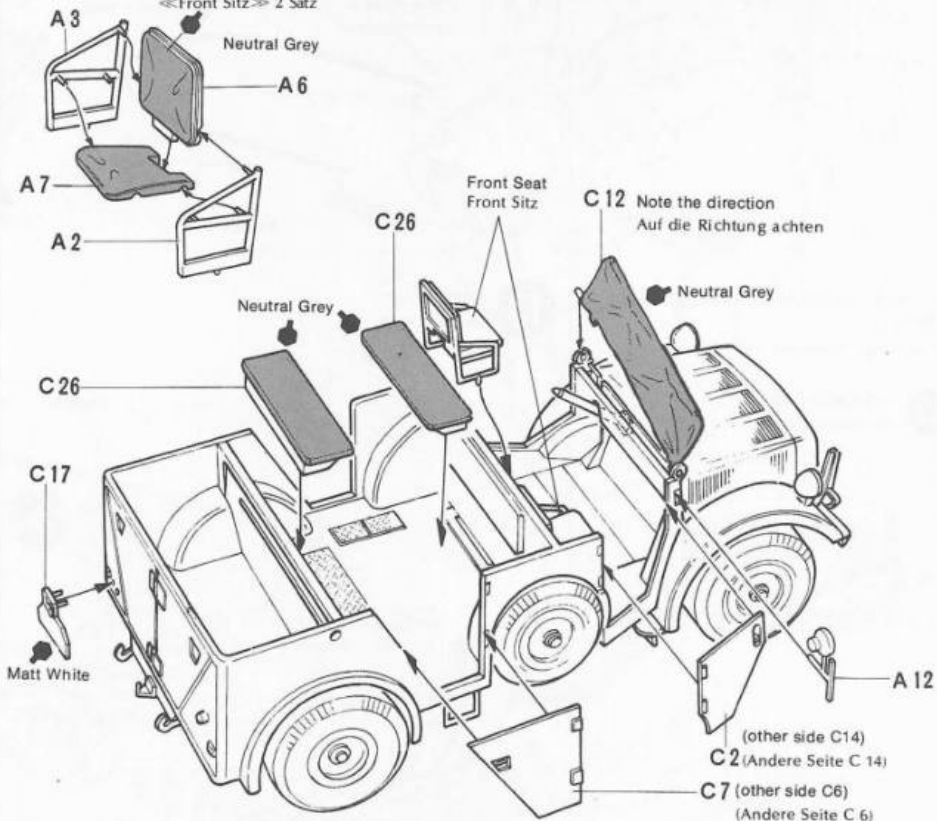

# 11 Construction and Painting of Figures

## Männchenbau

«Driver»  
 «Fahrer»

«Officer»  
 «Offizier»

«Noncommissioned Officer»  
 «Unteroffizier»

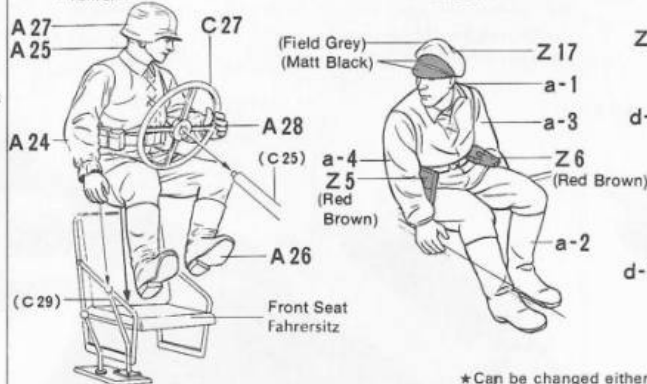

\* Can be changed either Z 18 or Z 19. Both of them can be used for every model figures without distinction of class.

«Soldier»  
 «Schütze»

«Soldier»  
 «Schütze»



**12** <<Wire Rope and Hood>>  
<<Schleppseil und Verdeck>>

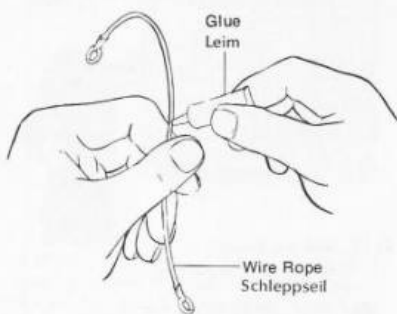

To lend additional realism, use diluted glue  
verdünntes Klebstoff verwenden

**12** Wire Rope and Hood  
Schleppseil und Verdeck

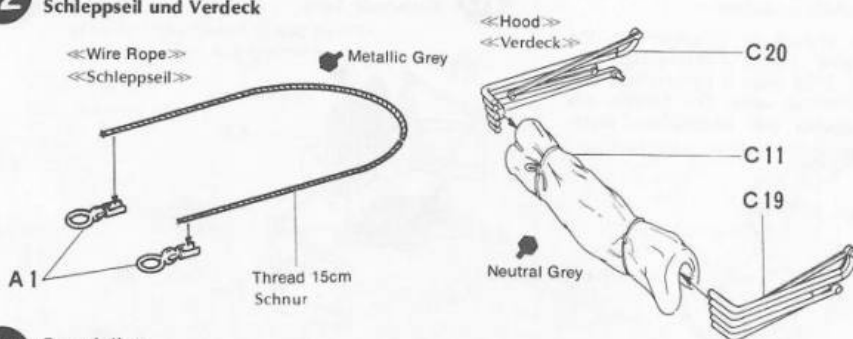

**13** Completion  
Endmontage

**13** <<Completion>>  
<<Endmontage>>

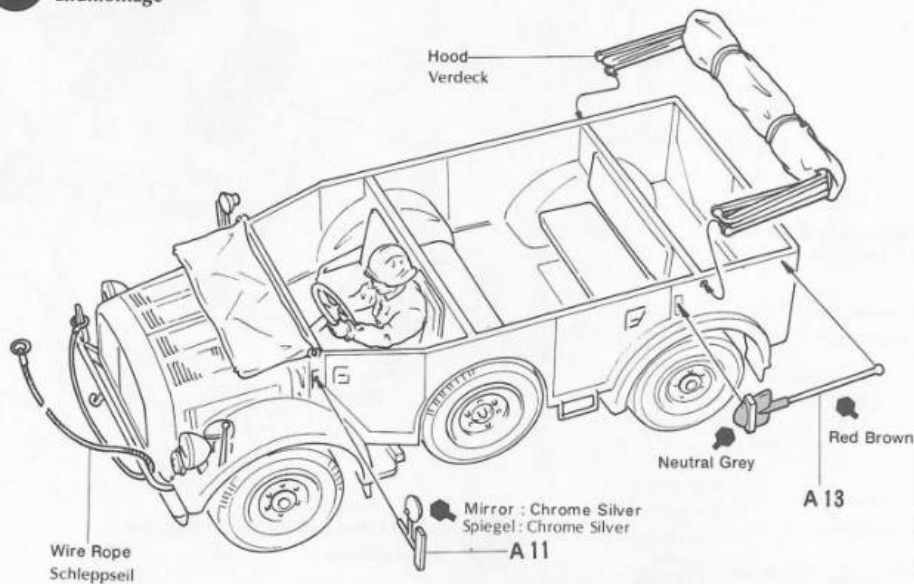
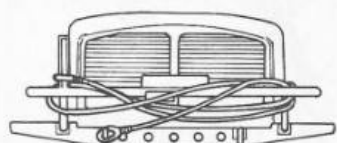

**BUILD A COLLECTION OF TAMIYA 1/35 SCALE TANK AND ARMORED CAR MODELS**

**FLAKPANZER IV MÖBELWAGEN**



**U.S. LVTP7A1**



**KRUPP PROTZE**

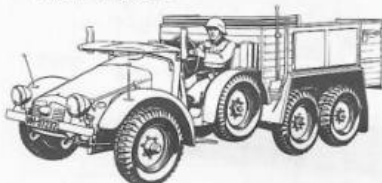

<<Figures and Accessory Parts>>  
<<Figur und Zubehör>>

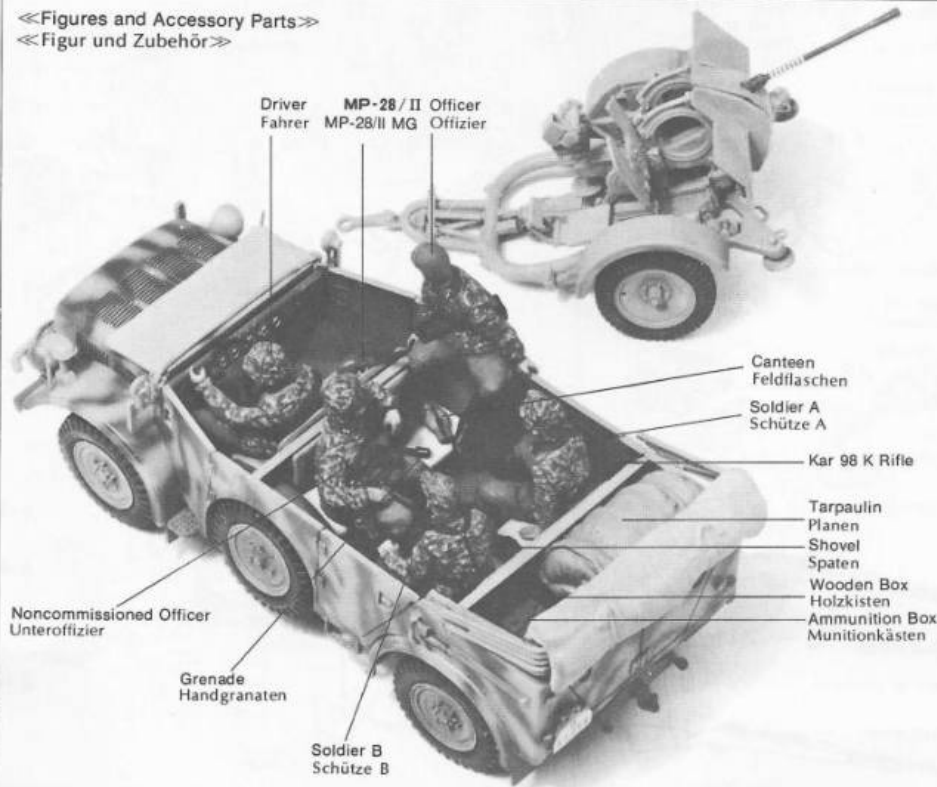



Please read this before commencing assembly

★ Study the instructions and photographs before commencing assembly.  
 ★ You will need a sharp knife, a pair of pliers, a file and a pair of tweezers.  
 ● This mark shows the colour

★ Vor Beginn die Bauanleitung Studieren und den Nummern nach die Elemente zusammenbauen.  
 ★ Kleine Teile hält man mit Pinzette fest.

● Zeichen für Bemalung.

## 1 Machine Gun Bases M.G. Lafette

«2cm Machine Gun»  
 «20 mm Maschinengewehr»

Gun Metal

«M.G. Base (left)»  
 «M.G. Lafette (links)»

«M.G. Base (right)»  
 «M.G. Lafette (rechts)»

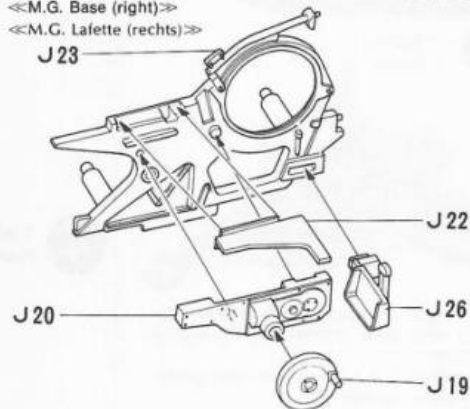
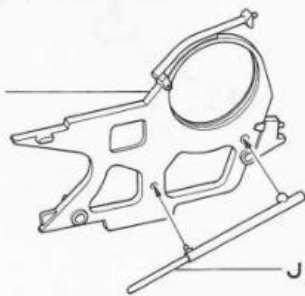

## 2 Fixing of Machine Gun Bases MG. Drehplatte

M.G. Base (left)  
 M.G. Lafette (links)

2cm Machine Gun  
 20 mm Maschinengewehr

«Seat»  
 «Sitz»

Red Brown

M.G. Base (right)  
 M.G. Lafette (rechts)

J 34  
 Fix D34 first  
 Erst D34 einbauen

«Shield»  
 «Schild»

J 18

J 12

Seat  
 Sitz

J 31

J 33

J 10

J 11

J 32

**Tamiya Acrylic Paints**  
 Need precise colour matching?  
 Try the new Tamiya acrylic paints. Engineered by modelers for modeler's use. The final cover for the finest models. Insist on Tamiya for perfect results.



**TAMIYA COLOR CATALOGUE**  
 The latest in cars, boats, tanks and ships. Motorized, radio controlled and museum quality models are all shown in full color in Tamiya's latest catalogue. At your nearest hobby supply house.

**3** <<Firing Platform>>  
<<Einbau der Drehplatte>>

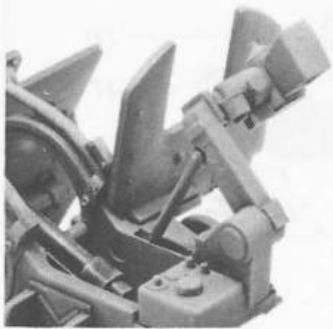

**4** <<Trailer>>  
<<Protze>>

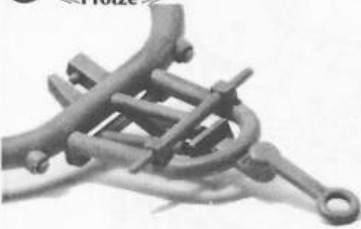

\* Fixing of accessory parts D16 may be done with your preference in firing position.  
\* Zubehör D16 kann wie im Bild gezeigt eingebaut werden.

**3** Firing Platform  
Drehplatte

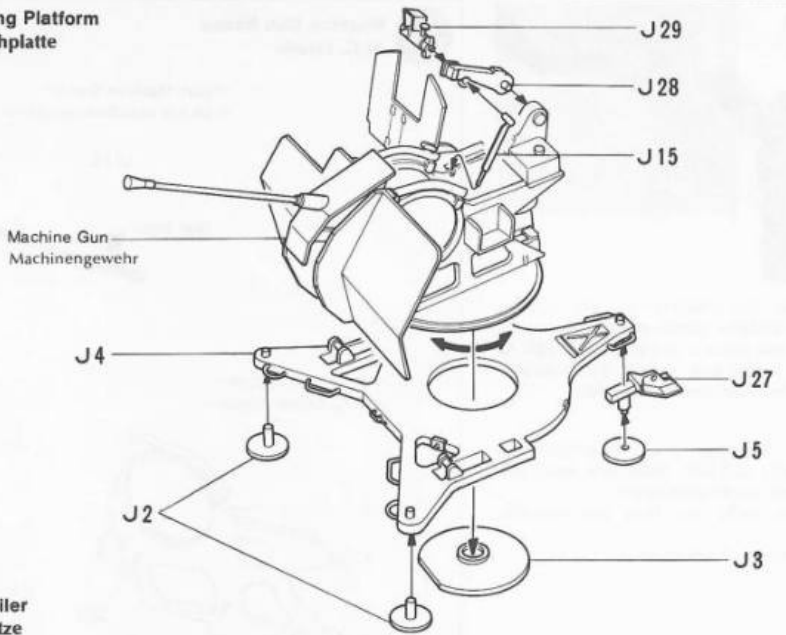

**4** Trailer  
Protze

<<Construction 1>>  
<<Zusammenbau 1>>

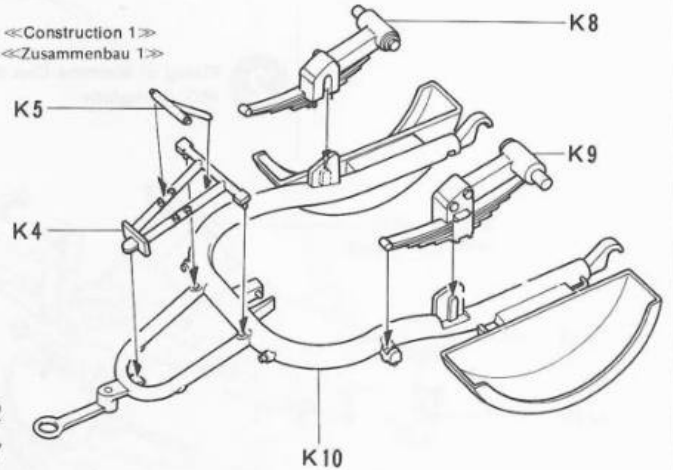

<<Construction 2>>  
<<Zusammenbau 2>>

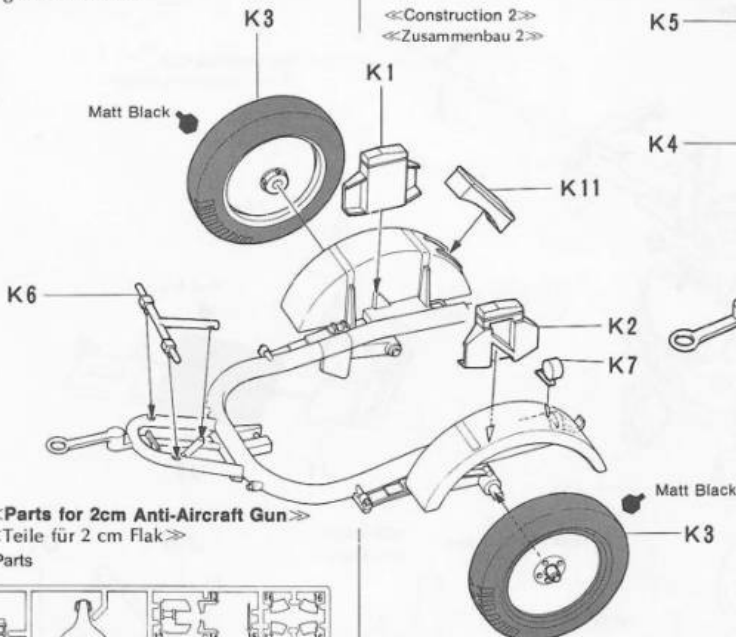

<<Parts for 2cm Anti-Aircraft Gun>>  
<<Teile für 2 cm Flak>>  
J Parts

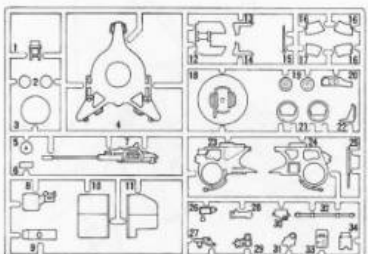

K Parts

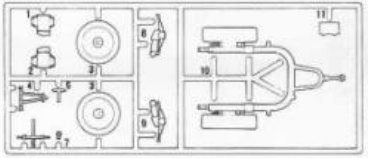

**5** Trailer  
Protze

\* Do not cement but just insert.  
\* Nicht kleben-nur einstecken

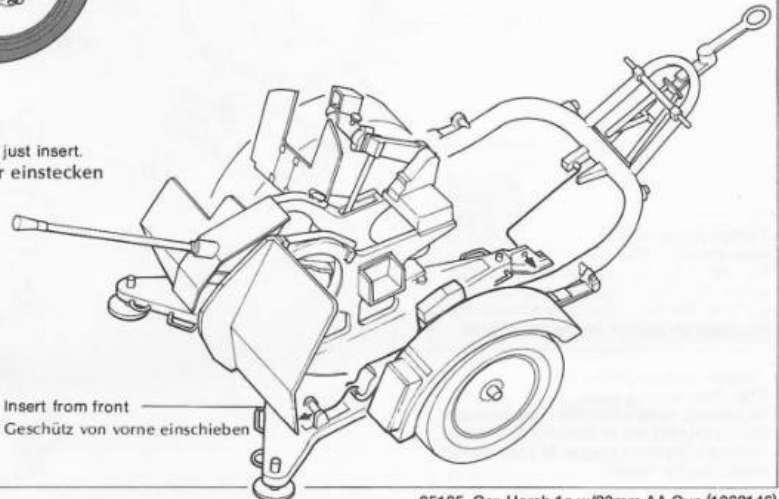

# PAINTING



# APPLYING DECALS

Da die Farben unter der englischen Bezeichnung zu erhalten sind, geben wir nur die englischen Namen an. **Keine Farben auf Nitrobasis verwenden!!!** Wir übernehmen keine Haftung für Schäden die durch falsche Farbenwahl entstehen. Nur **Farben verwenden, die für Polystyrol Plastik geeignet sind.**

### <<Painting of the Horch Type 1a>>

German military vehicles were painted differently according as they were used before or after August 1943. Before that time, German military vehicles in Europe were painted in the basic colour of German Grey and those in Africa wore uniform painting of dark yellow, reddish-brown camouflage pattern on a dark-yellow ground or darkgreen camouflage pattern on a German Grey ground. In August 1943, the German military authorities ordered to use only dark yellow as the basic colour. The Horch 1a manufactured in 1937-41 was painted in German Grey (Europe) or dark yellow (Africa).

### <<Bemalung>>

Vor August 43 waren alle Militärfahrzeuge je nach Einsatzort bemalt. Europa - dunkelgrau, Afrika - dunkelgelb, Tarnflecken wurden auf gelb in rotbraun und auf grau mit dunkelgrün gemalt. Ab September 43 wurden dann alle Fahrzeuge in einheitlichem dunkelgelb ausgeliefert und erst am Einsatzort mit Tarnfarben bemalt.

### <<Marking of the Horch Type 1a>>

German military vehicles wore divisional marks and tactical marks. Vehicles of the Afrika Korps used corps marks in addition to them.

### <<Markierung der Horch 1a>>

Die deutschen Fahrzeuge hatten Divisions- und taktische Zeichen. Im Afrikaeinsatz waren zusätzlich Corpszeichen angebracht.

### <<Divisional Mark>>

European Theatre

Wermacht Car No. WH



 Grossdeutschland  
Panzer Grenadier Div.

Waffen SS Car No. SS

 "Adolf Hitler"  
1st SS Pz. Div.  "Das Reich"  
2nd SS Pz. Div.

 "Totenkopf"  
3rd SS Pz. Div.

Luftwaffe Car No. WL



  Hermann Göring  
Pz. Div.

African Theatre Car No. WH

 294th Infantry  
Div.  Symbol of  
Afrika  
Korps

Tactical Mark

 Motorcycle  
Infantry  
Battalion  Mechanized  
Infantry  
Battalion

 Mechanized  
Artillery  
Battalion  Transportation  
Battalion

<<Vehicle on the European Theatre>>

<<Europa>>

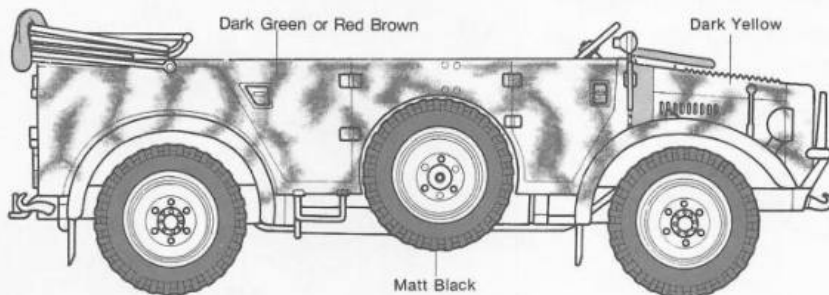

Divisional Mark  
Divisions Zeichen

Tactical Mark  
Takt. Zeichen

Tactical Mark  
Takt. Zeichen

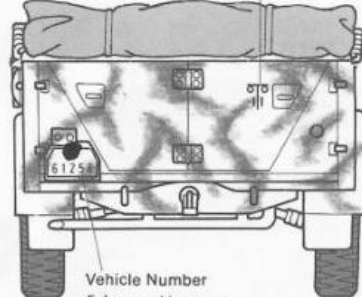
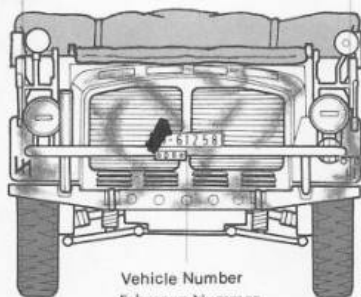

Neutral Grey

Neutral Grey

Neutral Grey

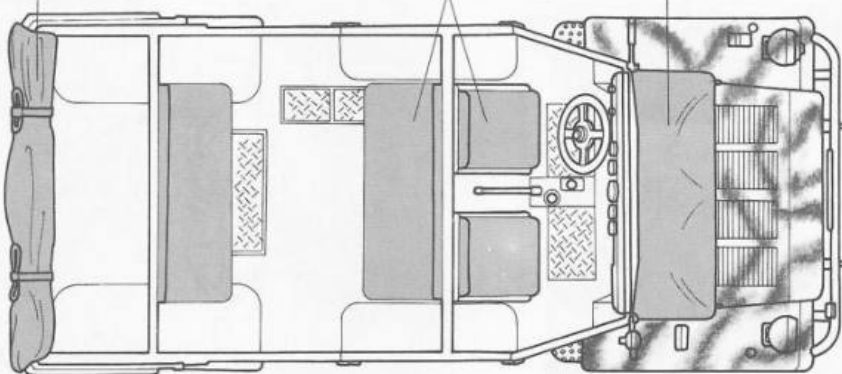

Kill Mark  
Abschussringe

Gun Metal

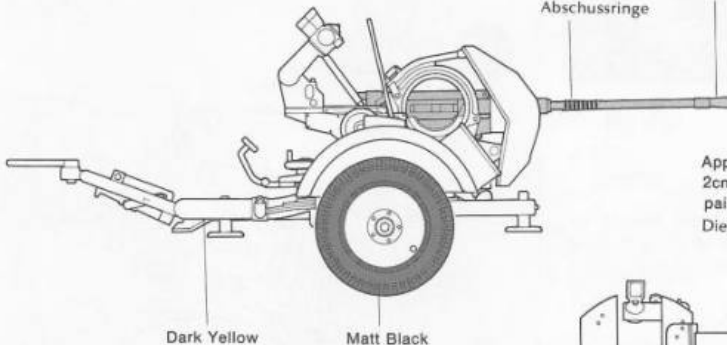

Apply this mark when  
2cm Flak Solo will be  
painted in German Grey  
Diese Zeichen bei grauer

\* 2cm Flak Solo should be painted  
in the same basic colour as Horch  
type 1a.

\* Die 2 cm Flak ist wie der Horch bemalt

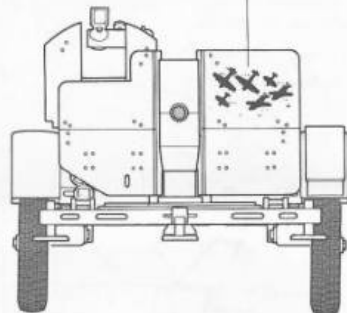

«Painting of Camouflage Suits»

Camouflage suits were supplied to the Nazi Waffen SS. Camouflage patterns and colours were chosen according to the season, terrain and action. The typical spring camouflage colours were green and brown, which formed various patterns. Such spring camouflage suits were worn also in summer. The main autumn camouflage colour was different shades of brown.

«Spring Camouflage Suits»

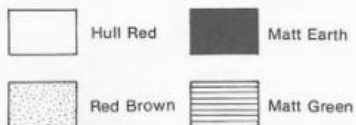

«Autumn Camouflage Suits»

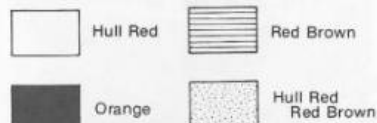

«Vehicle on the Afrikan Theatre»

«Afrika»

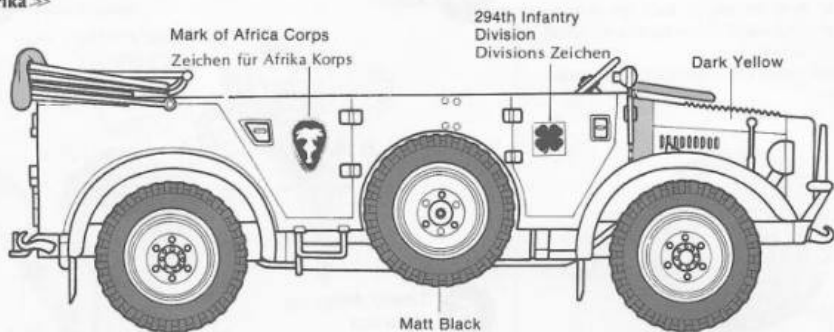

Divisional Mark  
Divisions Zeichen

Tactical Mark  
Takt. Zeichen

294th Infantry  
Division  
Divisions Zeichen

Mark of African Corp  
Zeichen für Afrika Korps

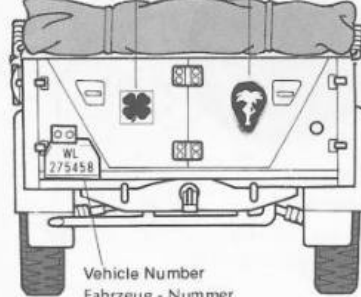
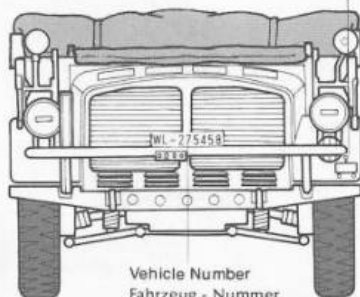

Vehicle Number  
Fahrzeug - Nummer

Vehicle Number  
Fahrzeug - Nummer

Neutral Grey

Neutral Grey

Neutral Grey

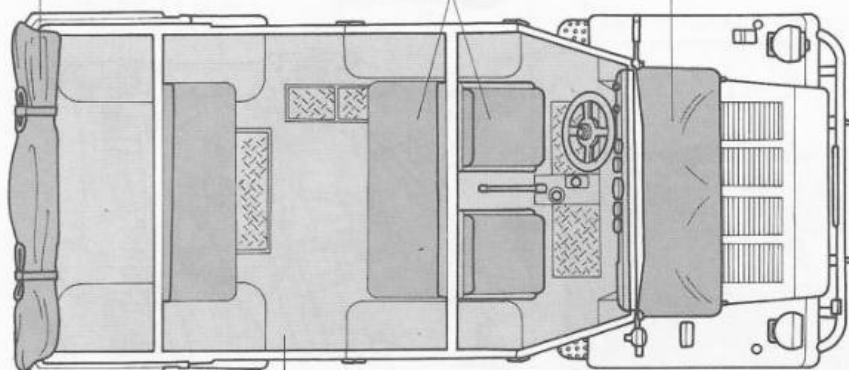

German Grey

Kill Mark  
Abschussringe

Gun Metal

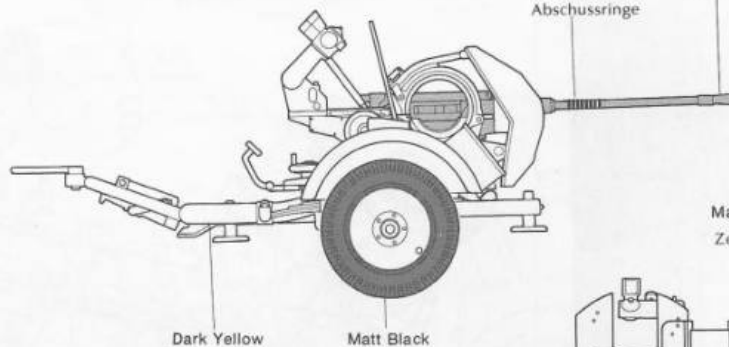

Dark Yellow

Matt Black

Mark of African Corp  
Zeichen für Afrika Korps

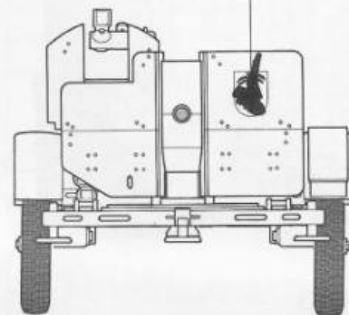

★ 2cm Flak Solo should be painted in the same basic colour as Horch type 1a.

★Die 2 cm Flak ist wie der Horch bemalt