

**DEUTSCH: ACHTUNG:** Vor dem Zusammensetzen die Bauanleitung gut durchlesen. Jedes Teil ist nummeriert. Reihenfolge der Montageschritte beachten. Benötigte Werkzeuge: Messer und Feile zum Entfernen und Entgraten der Teile, Gummiband, Klebeband und Wäschklammern zum Zusammenhalten der geklebten Einzelteile. Plastikteile in einer milden Waschlösung reinigen und an der Luft trocknen, damit der Farbenstrich und die Abziehbilder besser haften. Vor dem Ankleben prüfen, ob die Teile passen; Klebstoff sparsam auftragen. Chrom und Farbe an den Klebeflächen entfernen. Kleine Teile anstreichen, bevor sie vom Rahmen entlernt werden. Farben gut trocknen lassen, erst dann den Zusammenbau fortsetzen. Jedes Abziehbildmotiv einzeln ausschneiden und ca. 20 Sekunden in warmes Wasser tauchen. Das Motiv an der bezeichneten Stelle vom Papier abschieben und mit Löschpapier andrücken.

**ENGLISH: ATTENTION:** Carefully read instruction sheet before assembling. Each part is numbered. Consider succession of assembly steps. Required tools: knife and file to remove and trim parts; rubber band, adhesive tape and clothes pegs to hold parts after cementing. Wash plastic in mild detergent solution, rinse and let air dry for better paint and decal adhesion. Scrape chrome and paint at area to be glued: Paint small parts on runner before removing. Allow paint to dry thoroughly before continuing assembly. Cut out each decal one by one and dip it in warm water for approx. 20 secs.; slide decal from the paper at the marked position and dap with blotting-paper.

**FRANÇAIS: ATTENTION:** lire soigneusement la fiche d'instructions avant d'assembler. Chaque pièce est numérotée. Suivre la succession des étapes de montage. Outils nécessaires: couteau et lime pour détacher et ébarber les pièces, élastiques, papier adhésif et pinces à linge pour maintenir ensemble les pièces après collage. Laver le plastique dans une solution détergente légère, rincer et laisser sécher à l'air libre pour une meilleure adhérence de la peinture et des décalis. Ajuster les pièces ensemble avant de coller. Employer la colle Revell pour plastique exclusivement. Utiliser très peu de colle à chaque fois. Gratter le chrome ou la peinture sur les sur-faces à coller. Peindre les petites pièces sur le support avant de les détacher. Laisser la peinture sécher totalement avant de continuer l'assemblage. Découper chaque décal séparément et le plonger dans l'eau chaude environ 20 secondes. Faire glisser le décal du papier à l'endroit du décor et tamponner avec du papier buvard.

**NEDERLANDS: OPGELET:** alvorens te beginnen met het in elkaar zetten, eerst de handleiding goed doorlezen. Elk onderdeel is genummerd. Aandacht besteden aan de volgorde van montage. Het benodigde gereedschap: mesje en vijl voor het verwijderen en het afbramen van de onderdelen, elastiek, plakband en wasknijpers gebruiken voor het bij elkaar houden van de gelijmde onderdelen. De plastic onderdelen met een zacht wasmiddel schoonmaken en laten drogen zodat de verf en de transfers beter hechten. Alvorens te lijmen, eerst vaststellen of de onderdelen

passen; de lijm zuinig opbrengen. Chrom en verf van de op elkaar te lijmen delen verwijderen. Kleine onderdelen verven vóór deze van het gietraam verwijderd worden. De verf goed laten drogen en eerst dan verder gaan met de bouw. Elk transfer apart uitknippen en ca. 20 seconden in lauw/warm water leggen. Het transfer op de juiste plaats van het papier schuiven op het model en met vloeiend papier andrukken.

**SVENSKA: VIKTIGT:** Läs noggrant igenom instruktionerna innan du börjar bygga. Varje del är nummerad. Tänk igenom ordningsföljden för de olika momenten. Följande verktyg krävs: kniv och fil för att ta loss och putsa detaljerna, gummiband, tejp och klädnyppor för att hålla detaljerna på plats medan limmet torkar. Tvätta alla plastdetaljerna i mild tvålösning, skölj och låt lufttorka för att få färg och dekalerna att fästa bättre. Proppa alltid detaljerna innan du limmar. Använd endast Revells plastlim. Använd sparsamt med lim. Skrapa bort krom och färg från den yta som ska limmas: måla smådetaljerna innan du skär loss dem. Låt all färg torka ordentligt innan du fortsätter byggandet. Skär ut varje dekal för sig och blöt den i ljummet vatten i ungefär 20 sekunder, och låt dekalen glida av papperet och ner på det markerade läget: sug sedan försiktigt upp det mesta vattnet med läskpapper eller en tygrasa.

**ITALIANO: ATTENZIONE:** Leggere attentamente le istruzioni prima dell'assemblaggio. Ogni pezzo è numerato. Tener presente la successione delle fasi di assemblaggio. Attrezzi necessari: coltello e lima per rimuovere e rifinire le parti elastiche nastro adesivo e spilli per tenere le parti dopo averle incollate. Lavare la plastica con un detergente delicato, sciacquare e lasciar asciugare all'aria per una migliore adesione della vernice e delle "decal". Accoppiare le parti da incollare. Usare solamente "Revell plastic cement". Usare poco collante. Grattare la cromatura e la vernice nei punti da incollare. Dipingere i piccoli accessori sul supporto prima di rimuoverli. Far seccare bene la vernice prima di continuare nell'assemblaggio. Ritagliare una per una le "decal" ed immergerle in acqua tiepida per circa 20 secondi. Applicare ogni "decal" nella posizione segnata e tamponare con della carta assorbente.

**ESPAÑOL: ATENCIÓN:** cuidadosamente leer la hoja de instrucciones antes del montaje. Cada pieza es numerada, consideren la sucesión de las operaciones de montaje. Herramientas requeridas: cuchilla y lima para quitar y desbarbar las piezas, banda de caucho, cinta adhesiva y pinzas para sujetar las piezas, después de engomadas. Lavar el plástico en solución detergente suave, aclarar y dejar que se seque al aire para una mejor adhesión de la pintura y la calcomanía. Adaptar las piezas bien juntas antes de encolar. Solamente utilizar pegamento plástico Revell. Utilizar el pegamento cuidadosamente y sin exceso. Raspar el cromado y la pintura en la zona que ha de ser encolada: Pintar las piezas pequeñas giratorias antes de sacarlas. Dejar que la pintura se seque totalmente antes de continuar el montaje. Cortar cada calcomanía una por una y sumergirla en agua caliente durante aproximadamente 20 segundos. Deslizar la calcomanía del papel en la posición marcada y golpearla suavemente con el papel secante.



Kleben  
Glue  
A coller  
Lijmen  
Limmas  
Incollare  
Engomar



Nicht kleben  
Don't glue  
À ne pas coller  
Niet lijmen  
Timmas ej  
Non incollare  
No engomar



Anzahl der Arbeitsgänge  
Number of working steps  
Nombre d'étapes de travail  
Het aantal der bouwhandelingen  
Antal arbetsmoment  
Numero di passaggi  
Numero de operaciones de trabajo



Wahlweise  
Optional  
Facultatif  
Ter keuze  
Valfritt  
Facoltativo  
Opcional

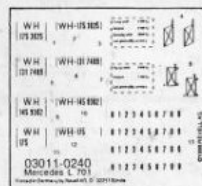

Abziehbild in Wasser einweichen und anbringen  
Soak and apply decals  
Mouiller et appliquer les décalis  
Transfer in water even laten weken en opbrengen  
Blöt och låst dekalerna  
Immergere in acqua ed applicare decal  
Remojar y aplicar las calcomanías



Abbildung zusammengebauter Teile  
Shown assembled  
Vu assemblé  
Afbeelding van een gebouwde onderdeel  
Visas hopsatt  
Figura ensamblada  
Presentado montado



Klarsichtteile  
Clear parts  
Pièces transparentes  
Transparente onderdelen  
Genomskinliga detaljer  
Parte trasparente  
Limpiar las piezas



Mit Messer schneiden  
Cut with knife  
Couper au couteau  
Met een mes snijden

<b>A</b> MATT SAND MATT SAND 16 SABLE MAT MAT ZAND MATT SAND SABBIA SMORTO	<b>B</b> LAKE GREEN SEGRÜN 48 VERT D'EAU ZEEGRÖEN HAUSGRÜN VERDE LAGO	<b>C</b> MATT BRICK MATT ZIEGELROT 37 ROUGE FONCE MAT MAT DONKER ROOD MATT MÖRK RÖD ROSSO SCURO SMORTO	<b>D</b> RUST RÖST 83 ROUILLE ROEST RÖST COLOR RUGGINE	<b>E</b> BLACK SCHWARZ 302 NOIR ZWART NERO	<b>F</b> METALLIC GREY EISENFARBIG 91 GRIS METALLIQUE IJZERKLEUR JARNGRÅ FERRO	<b>G</b> SILVER SILBER 90 ARGENT ZILVER SILVER ARGENTO	<b>H</b> ANTHRAZITE ANTHRAZIT 9 ANTHRACITE ANTHRACIET ANTRACIT ANTRACITE
<b>I</b> MATT FLESH MATT HAUTFARBE 35 COULEUR CHAIR MAT HUIDKLEUR MATT HUIDFARGAD COLOR PELLE SMORTO	<b>J</b> GREENISH GREY GRÜNGRAU 67 GRIS VERT GRÖENGRJIS GRÄGRÖN GRIGIOVERDE	<b>K</b> BROWN BRAUN 381 BRUN BRUIN BRUN MARRONE	<b>L</b> FIERY RED FEUERROT 31 ROUGE VERMILLON VUURROOD ELDRÖD ROSSO ACCESO				

WH 175325	WH-053025	1	2	3	4	5	6	7	8	9	10	11	12	13	14	15	16	17	18	19	20	21	22	23	24	25	26	27	28	29	30	31	32	33	34	35	36	37	38	39	40	41	42	43	44	45	46	47	48	49	50	51	52	53	54	55	56	57	58	59	60	61	62	63	64	65	66	67	68	69	70	71	72	73	74	75	76	77	78	79	80	81	82	83	84	85	86	87	88	89	90	91	92	93	94	95	96	97
WH 1317488	WH-017488	1	2	3	4	5	6	7	8	9	10	11	12	13	14	15	16	17	18	19	20	21	22	23	24	25	26	27	28	29	30	31	32	33	34	35	36	37	38	39	40	41	42	43	44	45	46	47	48	49	50	51	52	53	54	55	56	57	58	59	60	61	62	63	64	65	66	67	68	69	70	71	72	73	74	75	76	77	78	79	80	81	82	83	84	85	86	87	88	89	90	91	92	93	94	95	96	97
WH 1453322	WH-053322	1	2	3	4	5	6	7	8	9	10	11	12	13	14	15	16	17	18	19	20	21	22	23	24	25	26	27	28	29	30	31	32	33	34	35	36	37	38	39	40	41	42	43	44	45	46	47	48	49	50	51	52	53	54	55	56	57	58	59	60	61	62	63	64	65	66	67	68	69	70	71	72	73	74	75	76	77	78	79	80	81	82	83	84	85	86	87	88	89	90	91	92	93	94	95	96	97
WH 075	WH-075	1	2	3	4	5	6	7	8	9	10	11	12	13	14	15	16	17	18	19	20	21	22	23	24	25	26	27	28	29	30	31	32	33	34	35	36	37	38	39	40	41	42	43	44	45	46	47	48	49	50	51	52	53	54	55	56	57	58	59	60	61	62	63	64	65	66	67	68	69	70	71	72	73	74	75	76	77	78	79	80	81	82	83	84	85	86	87	88	89	90	91	92	93	94	95	96	97

03011-0240  
Mercedes L 701  
Reparatur-Geleitkarte (Repar. A.S.D. 3019) (Repar.)

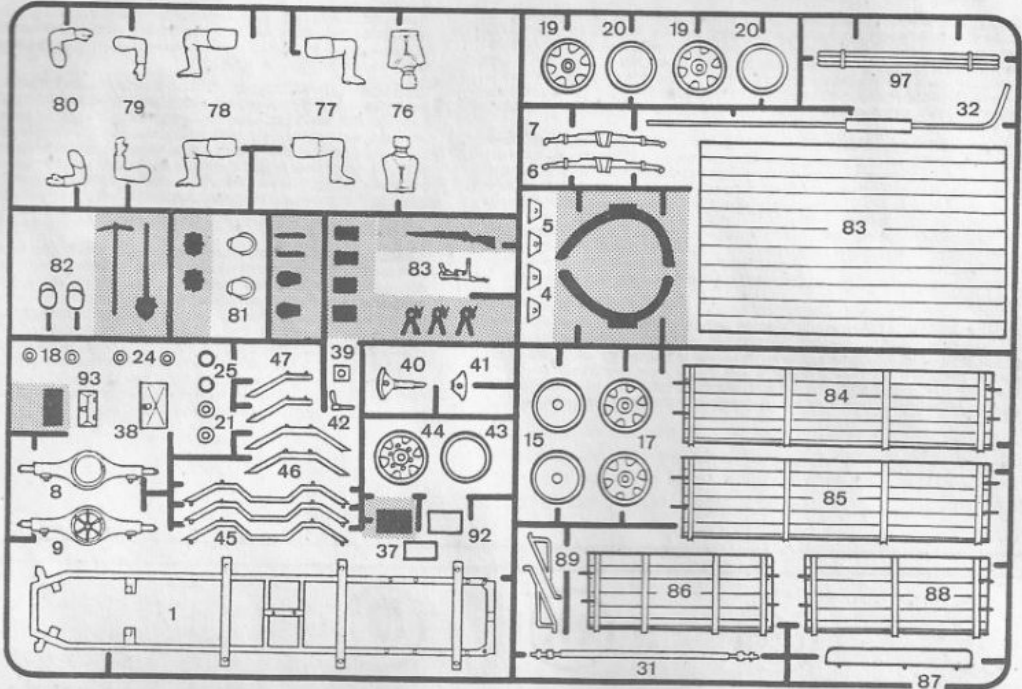
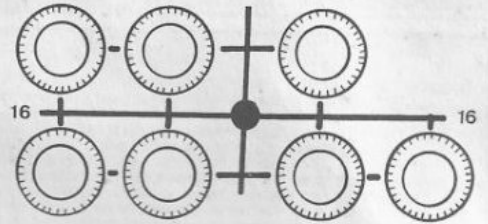
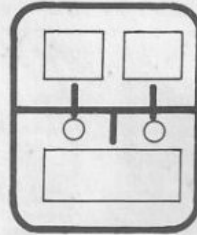

PARTS NOT USED  
NIGHT BENODIGTE BAUTEILE  
PIECES NON UTILISEES

DEELN NIET GEBRUIKT  
DELAR INTE ANVANDA  
PARTI NON USATE

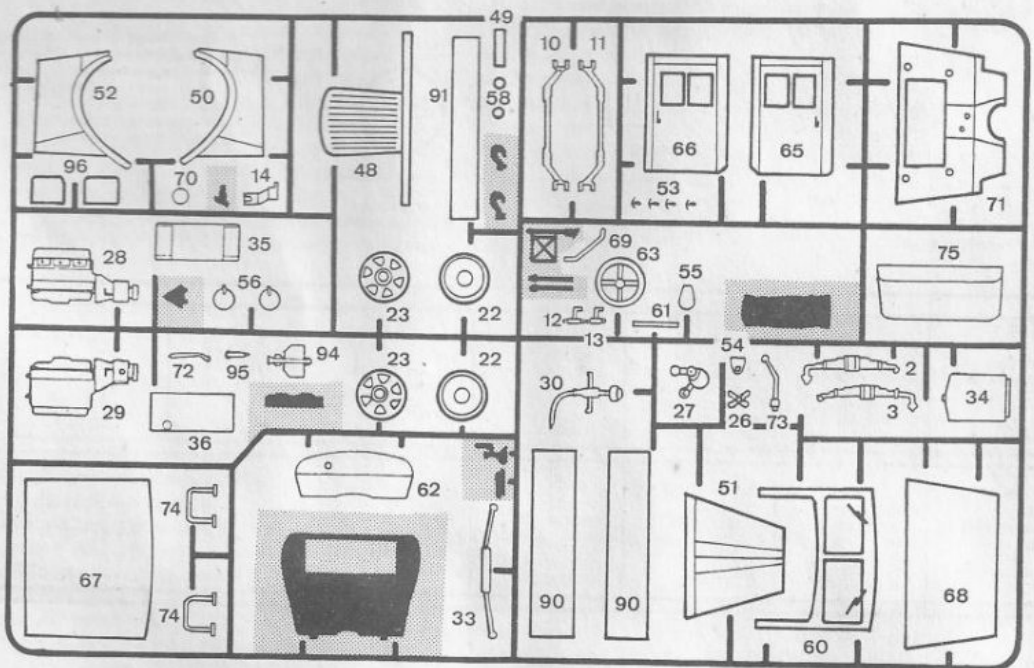

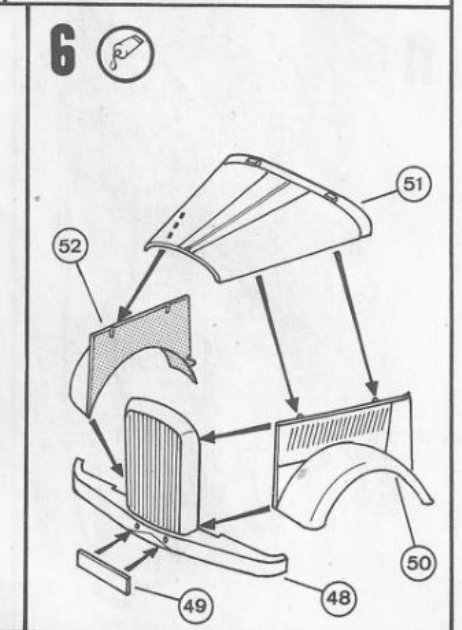
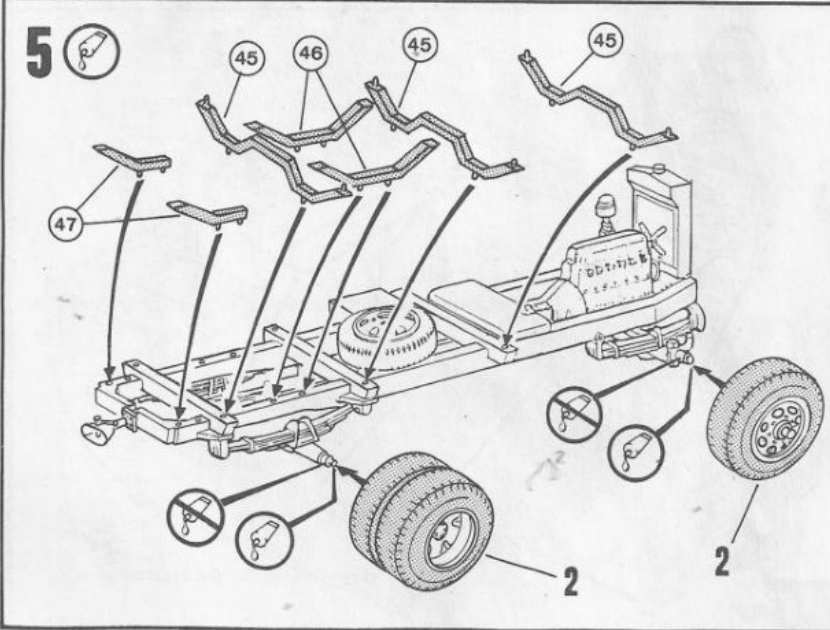
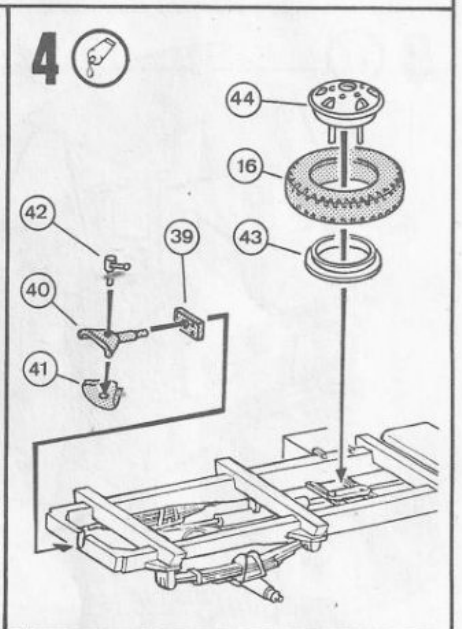
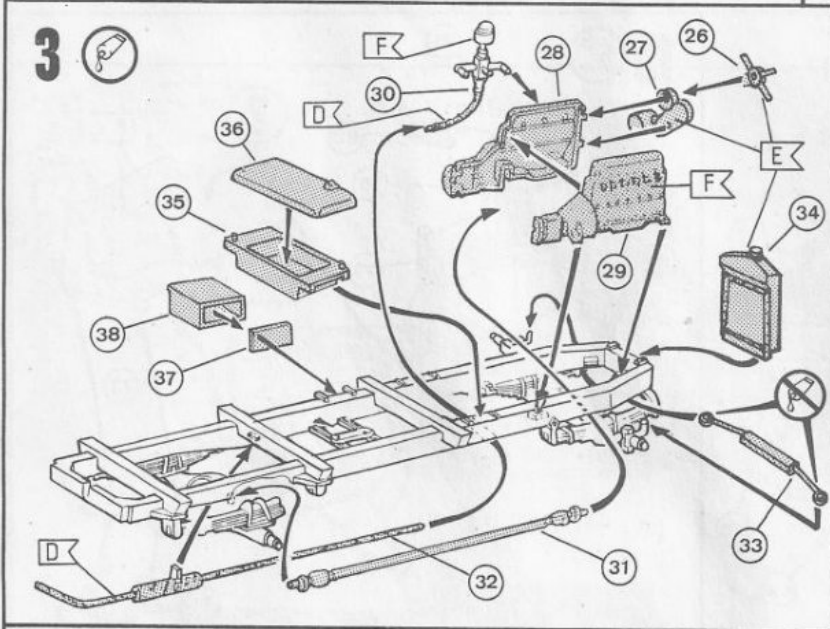
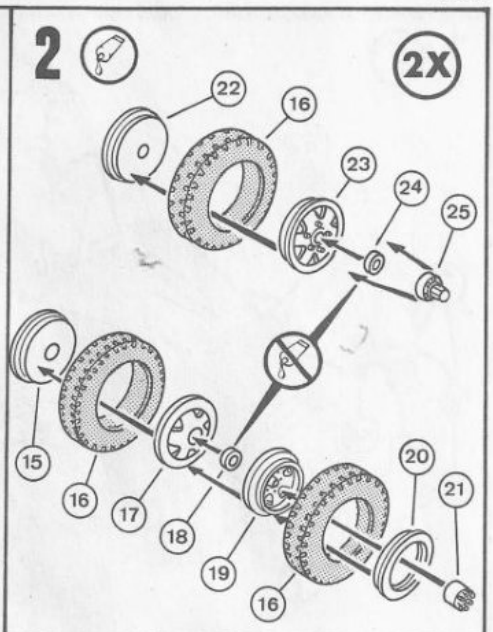
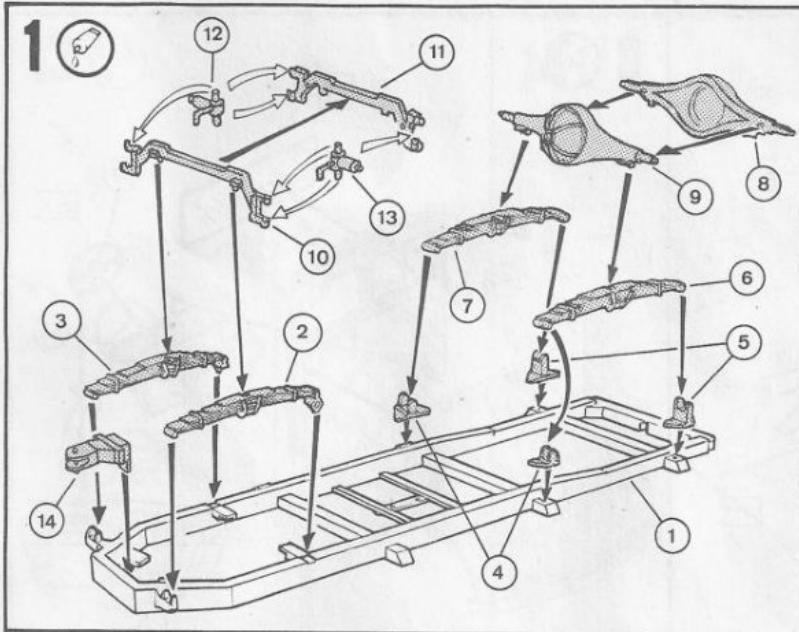

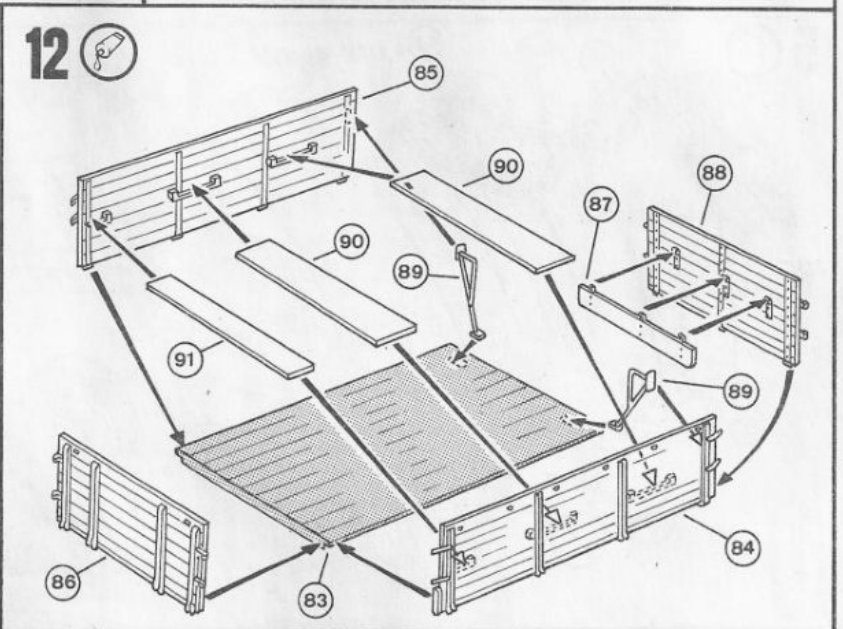
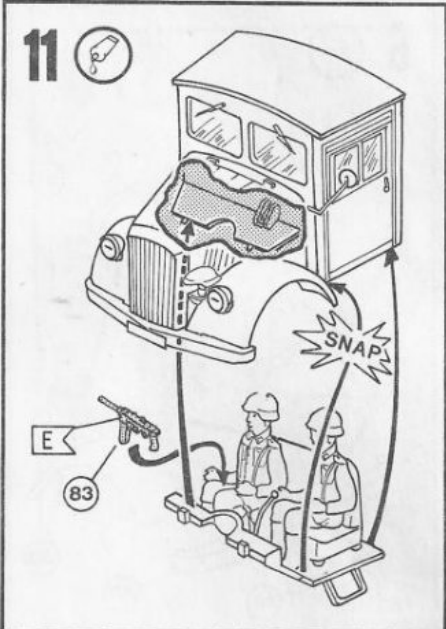
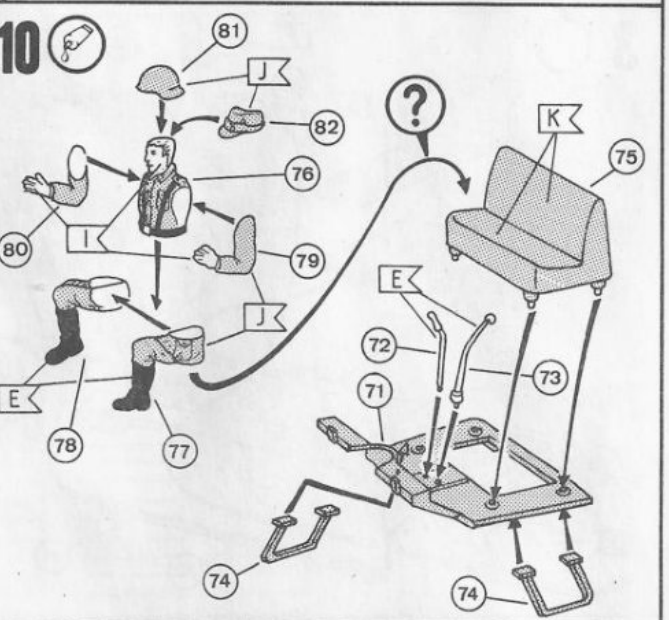
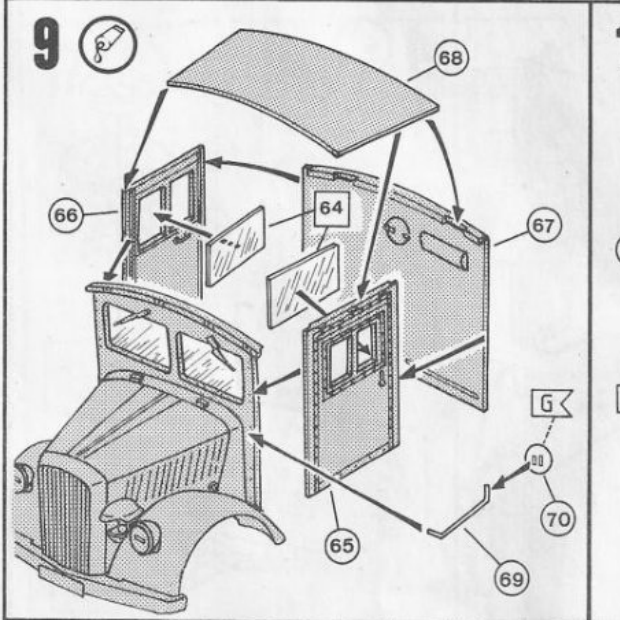
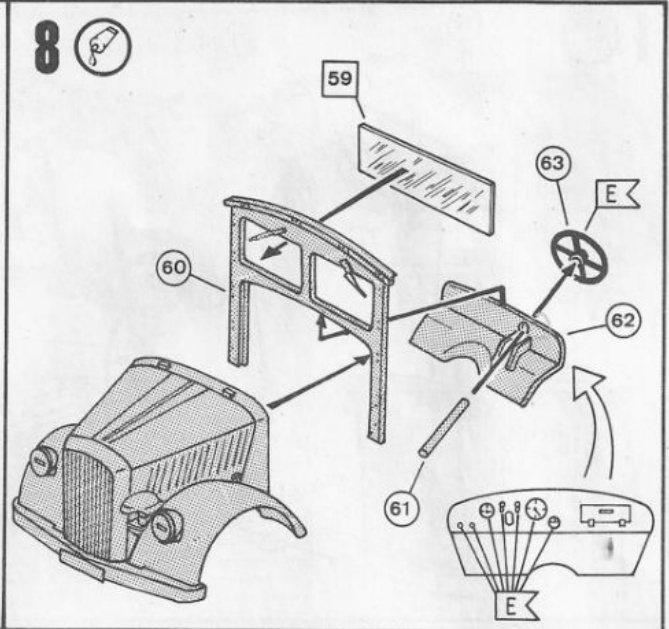
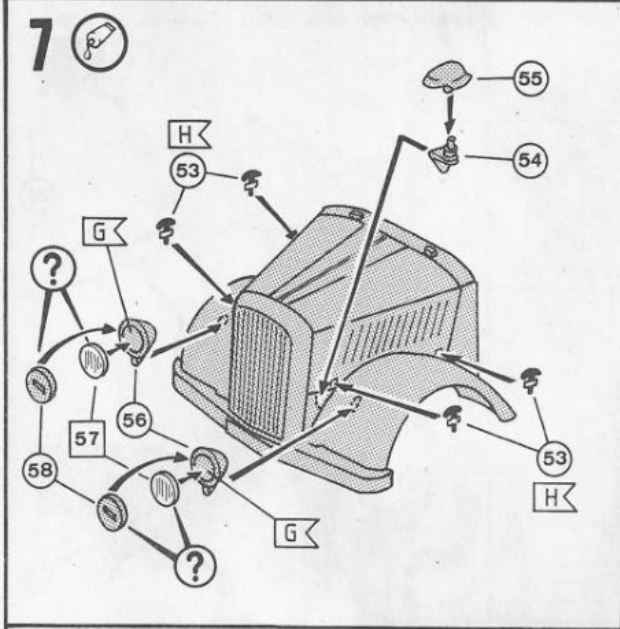

13 

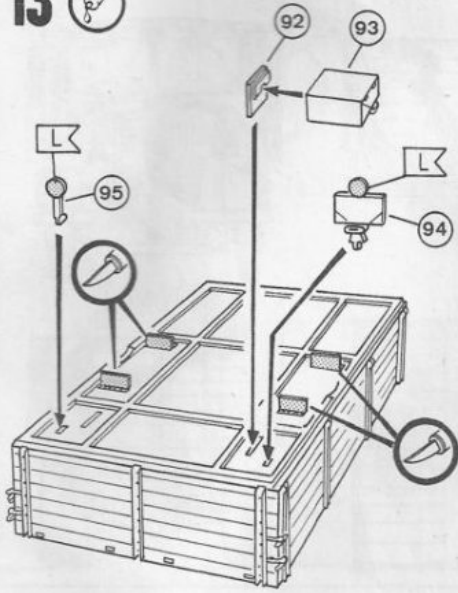

14 

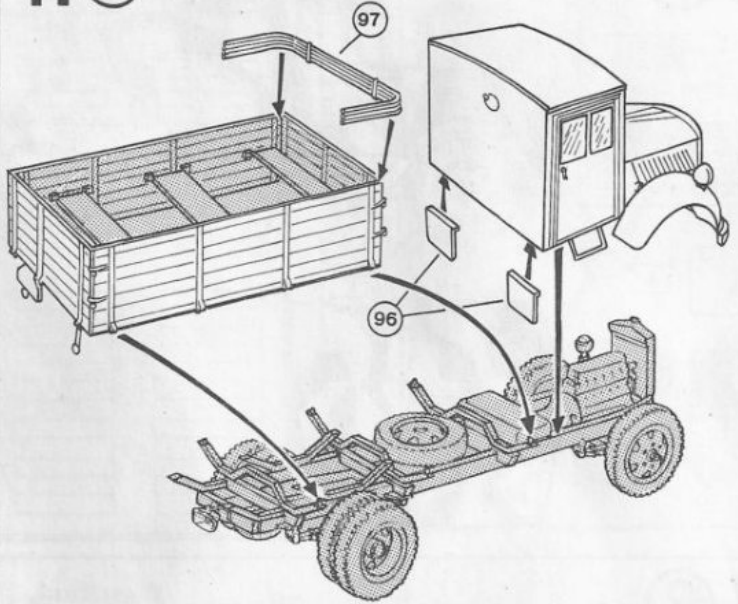

15

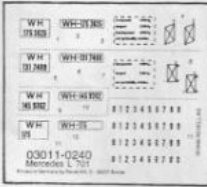

Westfront, April 1945

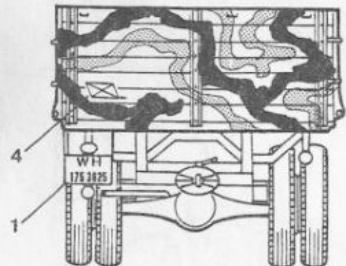
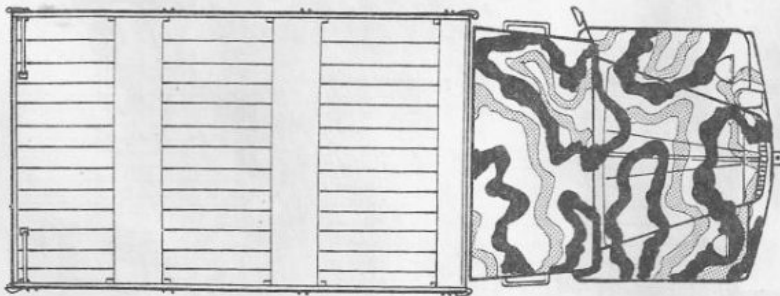
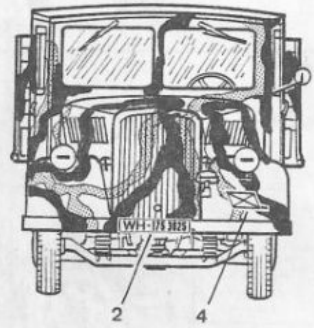
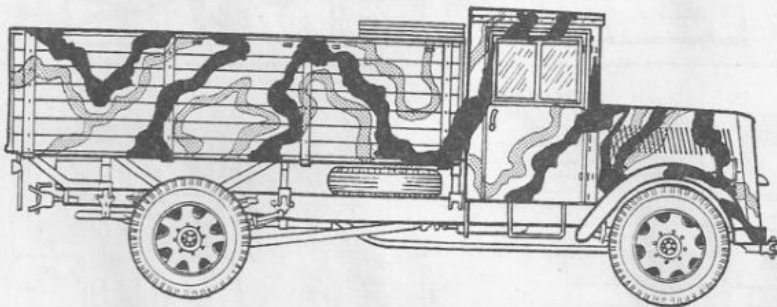
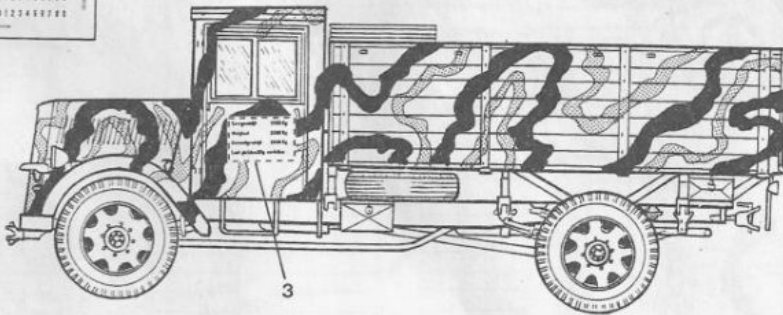
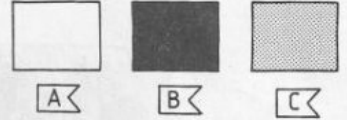

# 16 ?

## Ostfront, Herbst 1944

WH	US 3003	WH-03 3003	0123456789
WH	US 3003	WH-03 3003	0123456789
WH	US 3003	WH-03 3003	0123456789
WH	US 3003	WH-03 3003	0123456789
03011-0240			0123456789
Mercedes L 701			0123456789

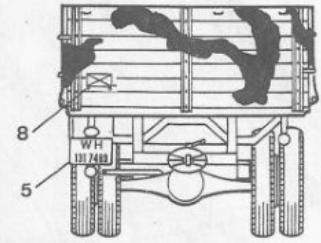
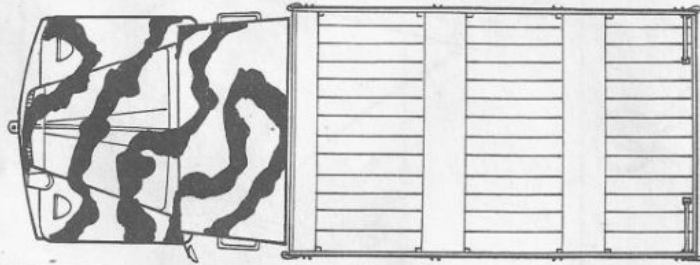
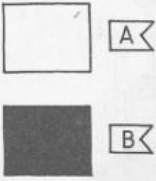
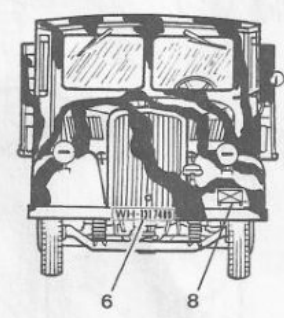
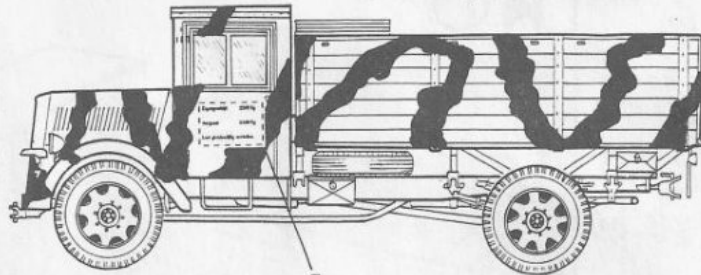

# 17 ?

## Westfront, 1945

WH	US 3003	WH-03 3003	0123456789
WH	US 3003	WH-03 3003	0123456789
WH	US 3003	WH-03 3003	0123456789
WH	US 3003	WH-03 3003	0123456789
03011-0240			0123456789
Mercedes L 701			0123456789

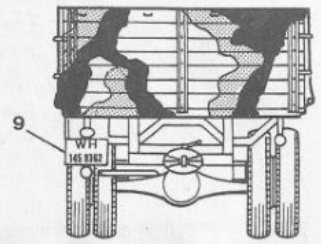
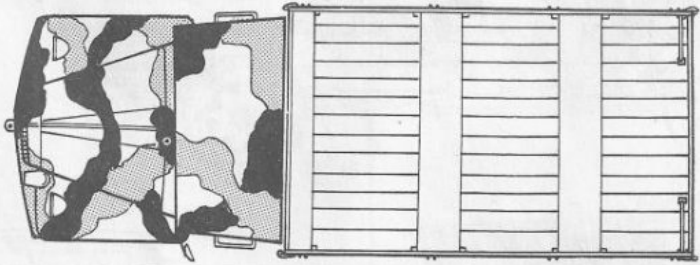
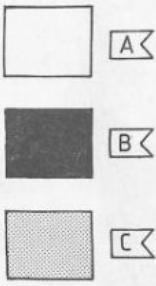
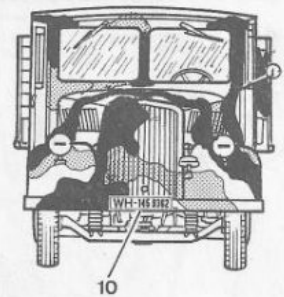
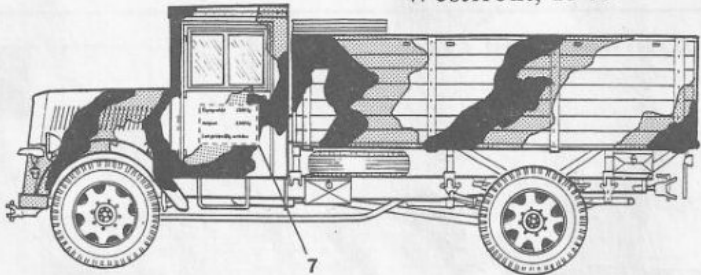

# 18 ?

## Ostfront, 1945

WH	US 3003	WH-03 3003	0123456789
WH	US 3003	WH-03 3003	0123456789
WH	US 3003	WH-03 3003	0123456789
WH	US 3003	WH-03 3003	0123456789
03011-0240			0123456789
Mercedes L 701			0123456789

