

6x4 TRUCK + KRUPP PROTZE

1/35 MILITARY MINIATURE SERIES



The original policy of the Wehrmacht when providing itself with motor transport was to use any suitable commercial type of trucks within certain laid down requirements. In the 'light' class a general specification for a 6 x 4 chassis had been drawn up by the old Reichswehr in 1929, before the army was reorganised and expanded under the Nazi regime. Several famous vehicle-makers in Germany produced designs in the light truck class which conformed to the 6 x 4 requirement, amongst them Büssing-NAG, Mercedes-Benz, and Magirus. However, by far the best known of these trucks, because of its distinctive characteristics, was the Krupp L2H 43 and its successor, the L2H 143. This vehicle was popularly known as the 'Boxer' because it had an air-cooled flat-four square engine. This in turn allowed a flat sloping engine cover of quite unmistakable shape which also gave excellent forward visibility and a low silhouette. The Krupp 'Boxer' was quite ubiquitous in application and the chassis carried body work for a considerable number of different roles. Aside from its air-cooled engine, the 'Boxer' also had an all-independent suspension system, differing from the conventional springing systems of other six-wheelers in German service. The L2H 43 was in production from 1933-36 and was replaced in production by the L2H 143 which was externally almost identical and differed only in mechanical and detail refinements. From about 1940 a new class of light truck was introduced in either 4 x 4 or 4 x 2 forms, a 1.5 ton vehicle or 1500 as it was usually designated by the makers. This new type was part of the Schell-Programm of standard types intended to cut down on the many different models previously in service and to standardise components. This type brought Krupp L2H 143 produc-

tion to an end, but the Krupp 'Boxer' was to be seen in German service right up to the end of the war. The standard truck version of the Krupp L2H 143 had a Krupp M304 3308cc air-cooled engine which gave 52 bhp at 2500 rpm. It had a 2905mm wheelbase and a weight of 2600 kg. Overall length was 4950mm, and width was 1950mm. There was also an armoured version of this vehicle, mostly used for command purposes which was designated SdKfz 247. In normal service form, however, the 'Boxer' was fitted with a body suitable for its role and was designated accordingly in the Wehrmacht ordnance inventory. The personnel and 'limber' bodies were opentopped with wood-frame supports for canvas tilts, and canvas folding weather tops for the cab. The personnel carrier, used by infantry and other units, was designated 'Mannschaftskraftwagen (Kfz 70) mit Fahrgestell des leichter geländegängiger Lastkraftwagen(o)'. This long official title meant 'personnel carrier with special chassis of the light cross-country truck (standard commercial)'. In practice the actual ordnance number, Kfz 70, was used as a short description. Other versions with different bodies were Kfz 81 (light AA truck), Kfz 69 (limber wagon or prime mover for light guns), and Kfz 83 (searchlight truck - two forms). To the German soldiers, the Krupp L2H was known as the 'Krupp-Schnauzer'.

Bereits 1929 stellte die alte Reichswehr den Plan auf, den Truppentransport zu verbessern und so weit wie möglich, vorhandene Fahrzeuge zu verwenden. In der leichten Klasse sollte ein 6 x 4 Chassis eingesetzt werden. Die Wehrmacht übernahm diese Pläne und einige bekannte Hersteller wie Büssing, Mercedes und Magirus ua. fertigten Entwürfe nach den Anforderungen

für diese leichten 6 x 4 Fahrzeuge an. Die bekanntesten Fahrzeuge wurden der Krupp L2H 43 und dessen Nachfolger, der L2H 143. Allgemeine Bezeichnung war "BOXER". Das Fahrzeug hatte einen luftgekühlten Vierzylinder Motor unter einer nach Vorne schrägen Motorhaube, welche natürlich die Sicht nach Vorne ganz erheblich verbesserte.

Die Radeinzelaufhängung unterschied sich ebenfalls von allen anderen 6 Rad-Fahrzeugen in Deutschland.

Der L2H 43 wurde von 1934 - 37 gebaut und dann kam der L2H 143 in die Produktion - nach Aussen fast keine Änderungen, jedoch in der Mechanik. Ab Ende 1940 wurde infolge des Schell-Programmes (Einheits-PKW und Einheits-LKW) die Produktion eingestellt und auf die neuen 4 x 4 oder 4 x 2 1,5 Tonner (Fabr. Bez. 1500) hergestellt. Im Einsatz jedoch blieben die Krupp - Schnauzer dank ihrer Unverwundlichkeit. Der Standard LKW L2H 143 hatte einen Kruppmotor M 304 mit 3308 cc, luftgekühlt, 52 PS, 2500 rpm. Radstand 2905 mm, Länge 4950 mm, Breite 1950 mm. Gewicht 2600 Kilo.

Der Mannschaftstransportwagen und die Protzkarosse waren oben offen mit Holzspiegel und Segeltuchplane.

Weitere Ausführungen und Abarten : Kfz. 247 für Kommando und Späherunternehmen, Kfz. 70 Mannschaftstransportwagen, Kfz. 81 leichter Luftschutzkraftwagen, Kfz. 83 leichter Scheinwerferkraftwagen, Kfz. 69 Protz- oder Zugwagen für leichte Kanonen, dem deutschen Landser jedoch war der Krupp L2H - ob 43 oder 143 - bekannt als KRUPP - SCHNAUZER.



Read before
assembly
Erst lesen -
dann Bauen

★ Be sure to read the following instruction carefully before starting assembly work.

★ You will need a sharp knife, a screw-driver, a pair of tweezers, a file and a pair of pliers.

★ Do not break parts away from sprue, but cut off carefully with a pair of pliers.

★ Use glue sparingly. Use only enough to make a good bond. Apply glue to both parts to be joined.

★ Vor Beginn die Bauanleitung studieren und den Nummern nach die Elemente zusammenbauen.

★ Bauteile nicht vom Spritzling abbrechen, vorsichtig abschneiden oder abwickeln, Teil vor Kleben zusammenhalten, auf genauen Sitz achten. Nicht zuviel Klebstoff verwenden. Kleine Teile hält man mit Pinzette fest.

★ Abziehbilder vorsichtig von der Unterlage im Wasser abschieben, auf richtigen Sitz achten und gut trocknen lassen.

<<Colours>>

<<Bemalung>>

Matt Black
Matt Flesh
Khaki
Metallic Grey
German Grey
Red Brown
Field Grey
Gun Metal
Chrome Silver

1 Construction of Cockpit Fahrersitz

<<Fender: right>>
<<Schutzblech: rechts>>

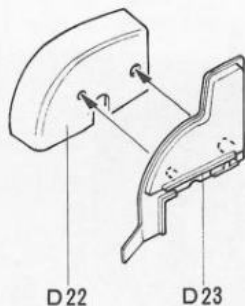

D22 D23

<<Fender: left>>
<<Schutzblech: links>>

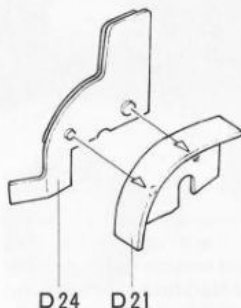

D24 D21

<<Cockpit>>
<<Fahrersitz>>

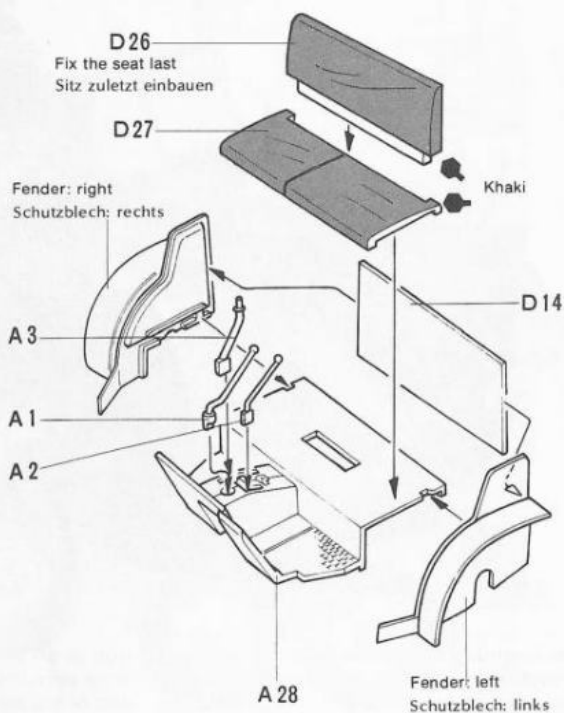

D26
Fix the seat last
Sitz zuletzt einbauen

D27

Fender: right
Schutzblech: rechts

Khaki

D14

A3

A1

A2

A28

Fender: left
Schutzblech: links

2 Engine Motor

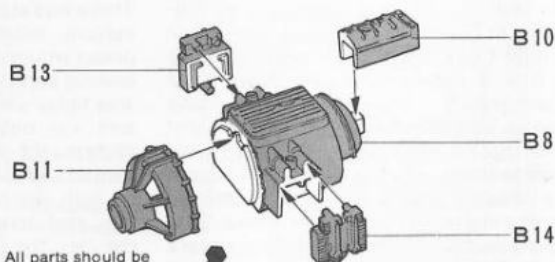

All parts should be
painted in Metallic Grey.
Alle Teile Metallic Grey bemalen.

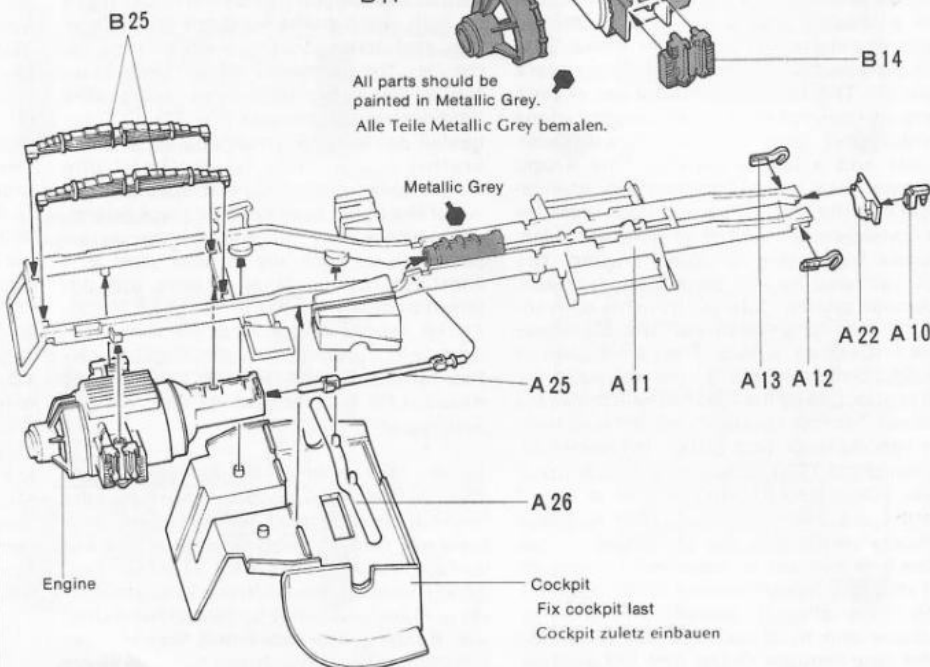

B25

B13

B10

B11

B8

B14

Metallic Grey

A25

A11

A13

A12

A22

A10

Engine

A26

Cockpit

Fix cockpit last

Cockpit zuletzt einbauen

1 <<Construction of Cockpit>> <<Fahrersitz>>

Fix fenders first. Seat D26, D27 should be fixed last.
Erst Schutzbleche, dann Sitze einbauen.

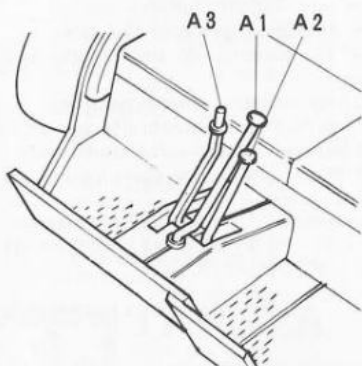

A3

A1

A2



Read before assembly
Erst lesen - dann Bauen

- ★ Be sure to read the following instruction carefully before starting assembly work.
- ★ You will need a sharp knife, a screwdriver, a pair of tweezers, a file and a pair of pliers.
- ★ Do not break parts away from sprue, but cut off carefully with a pair of pliers.
- ★ Use glue sparingly. Use only enough to make a good bond. Apply glue to both parts to be joined.

- ★ Vor Beginn die Bauanleitung studieren und den Nummern nach die Elemente zusammenbauen.
- ★ Bauteile nicht vom Spritzling abbrechen, vorsichtig abschneiden oder abzwicken, Teil vor Kleben zusammenhalten, auf genauen Sitz achten. Nicht zuviel Klebstoff verwenden. Kleine Teile hält man mit Pinzette fest.
- ★ Abziehbilder vorsichtig von der Unterlage im Wasser abschieben, auf richtigen Sitz achten und gut trocknen lassen.

<<Colours>>
<<Bemalung>>

- Matt Black
- Matt Flesh
- Khaki
- Metallic Grey
- German Grey
- Red Brown
- Field Grey
- Gun Metal
- Chrome Silver

1 <<Construction of Cockpit>> <<Fahrersitz>>

Fix fenders first. Seat D26, D27 should be fixed last.
Erst Schutzbleche, dann Sitze einbauen.

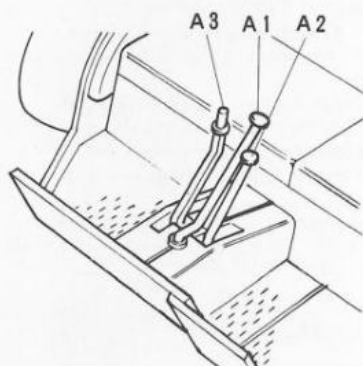

1 Construction of Cockpit Fahrersitz

<<Fender: right>>
<<Schutzblech: rechts>>

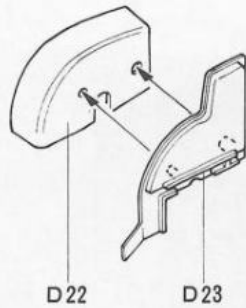

<<Fender: left>>
<<Schutzblech: links>>

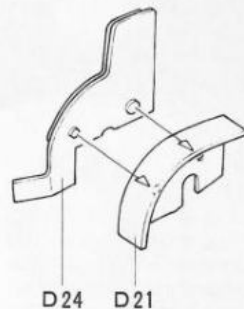

<<Cockpit>>
<<Fahrersitz>>

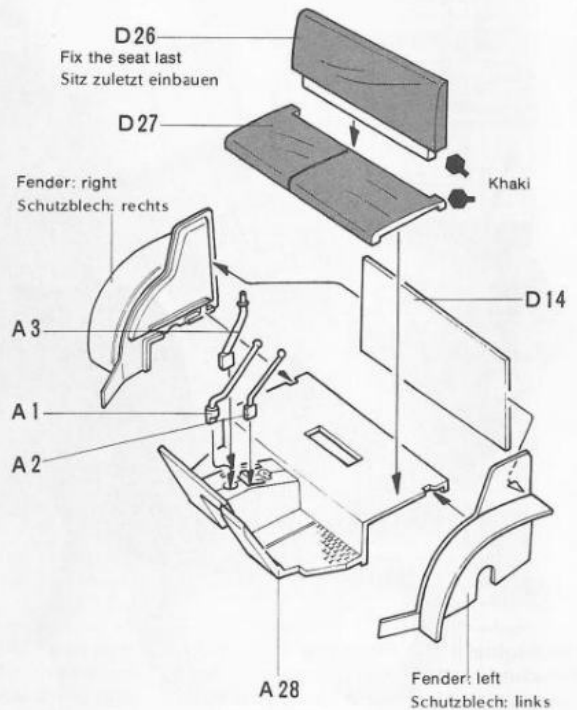

2 Engine Motor

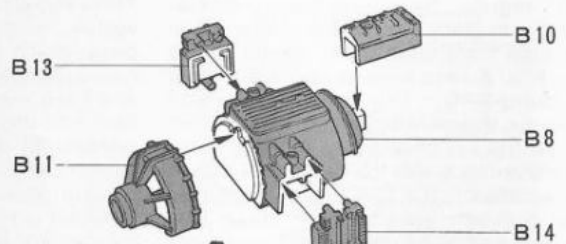

All parts should be painted in Metallic Grey.
Alle Teile Metallic Grey bemalen.

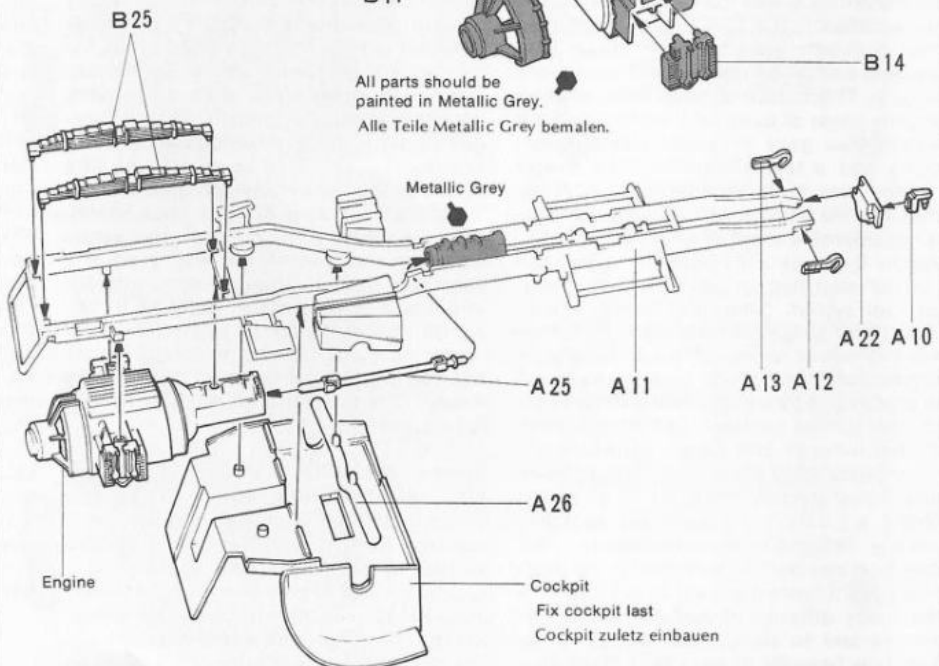

3 <<Rear Axle>>
<<Hint. Achsen>>

A21: do not assemble wrong way round
A21: nicht in der falschen Richtung
zusammenbauen.

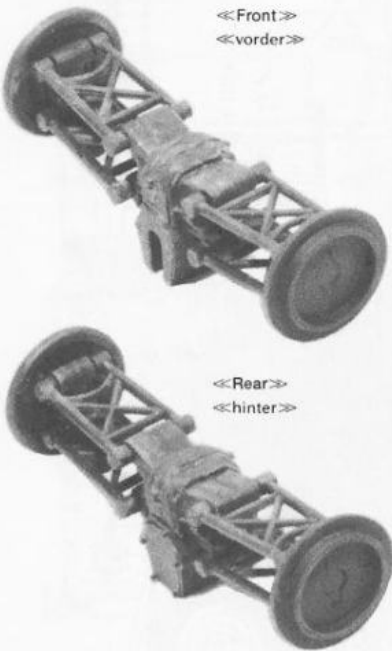

<<Fixing of A21>>
<<Schwinglager>>

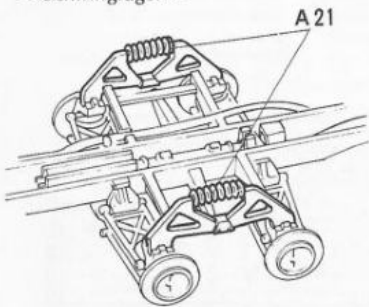

There are three kinds of wheels. Be careful of part numbers.

Es gibt 3 versch. Räder, auf Nummern achten.

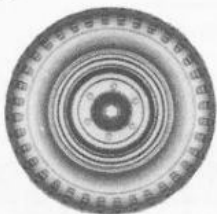

Front Wheel (B2) x 2
Vorderrad (B2) x 2



Rear Wheel (B1) x 4
Hinterrad (B1) x 4

3 Rear Axle
Hint. Achsen

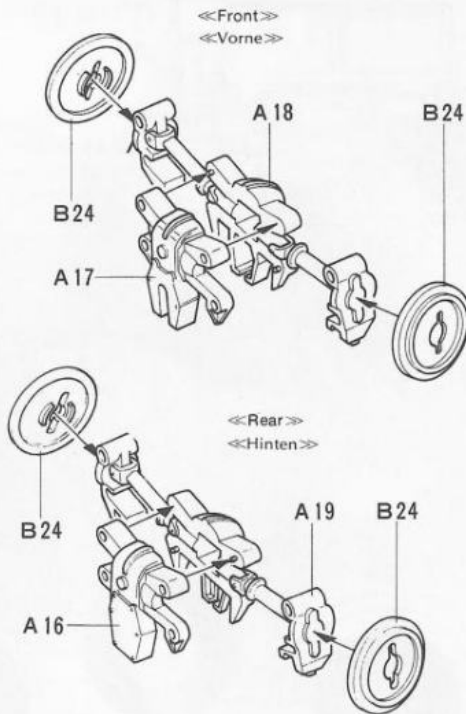

<<Suspension Arm>>
<<Achsenkerarme>>

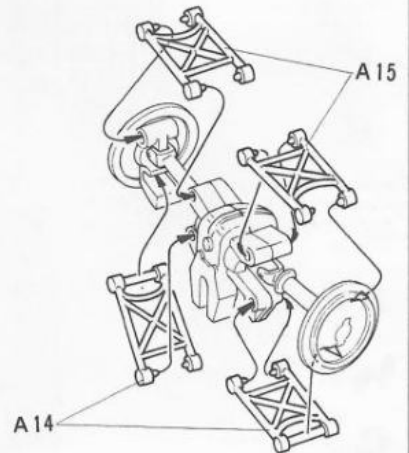

<<Fixing of Rear Axles>>
<<Einbau der hint. Achsen>>

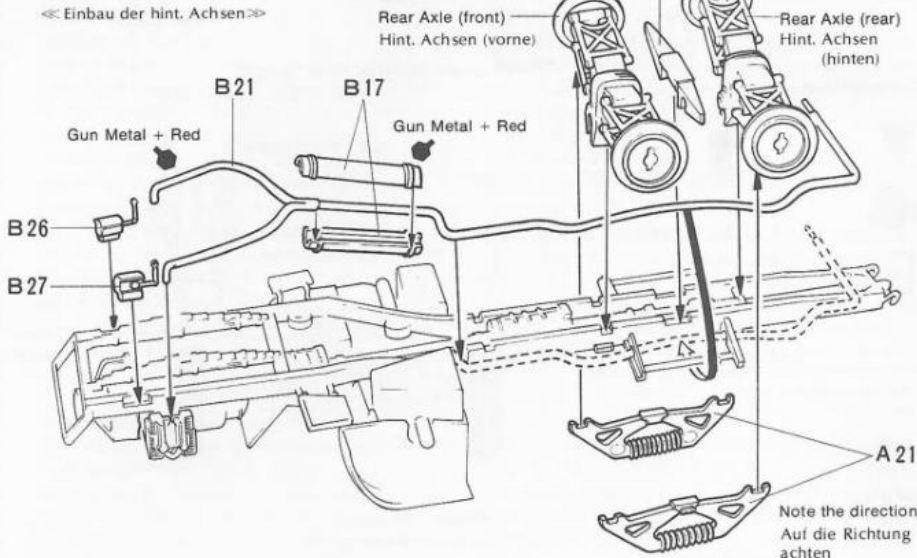

4 Wheels
Räder

<<Front Wheel>> Make 2 sets
<<Vorderrad>> 2 Satz

<<Rear Wheel>> Make 4 sets
<<Hinterrad>> 4 Satz

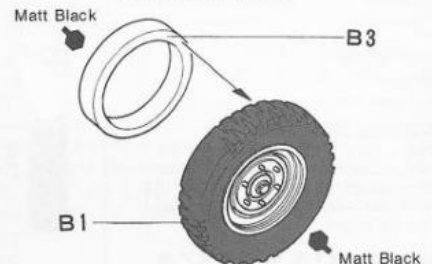
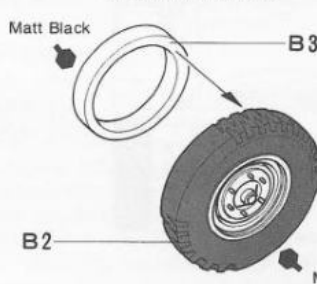

5 <<Front Axle>>
<<Radachse>>

Be careful of the direction of B23 and B28. If in the wrong direction, they can't be fixed in ⑥

Auf genaue Richtung der Teile B23 + B28 achten, sonst Einbau in Step ⑥ nicht möglich.

6 <<Fixing of Wheels>>
<<Einbau der Räder>>

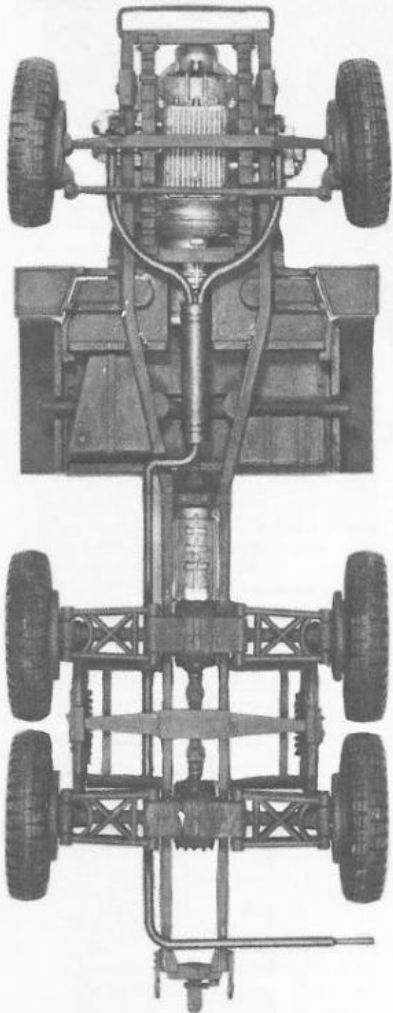

7 <<Engine Hood>>
<<Motorhaube>>

Transparent part for windshield should be cut out with a knife or scissors as shown in the figure below.

Transparentteil für Windschutzscheibe ausschneiden - siehe Bild.

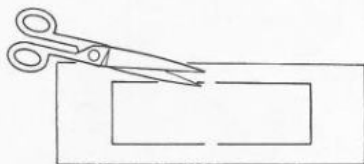

Tamiya Acrylic Paints
Need precise colour matching?
Try the new Tamiya acrylic paints. Engineered by modelers for modeler's use. The final cover for the finest models. Insist on Tamiya for perfect results.



5 Front Axle
Vorderachse

<<Construction 2>>
<<Zusammenbau 2>>

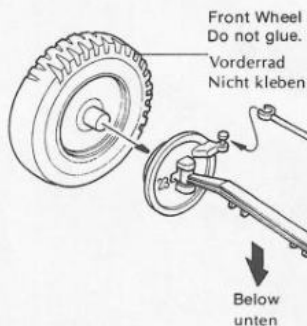

6 Fixing of Wheels
Einbau der Räder

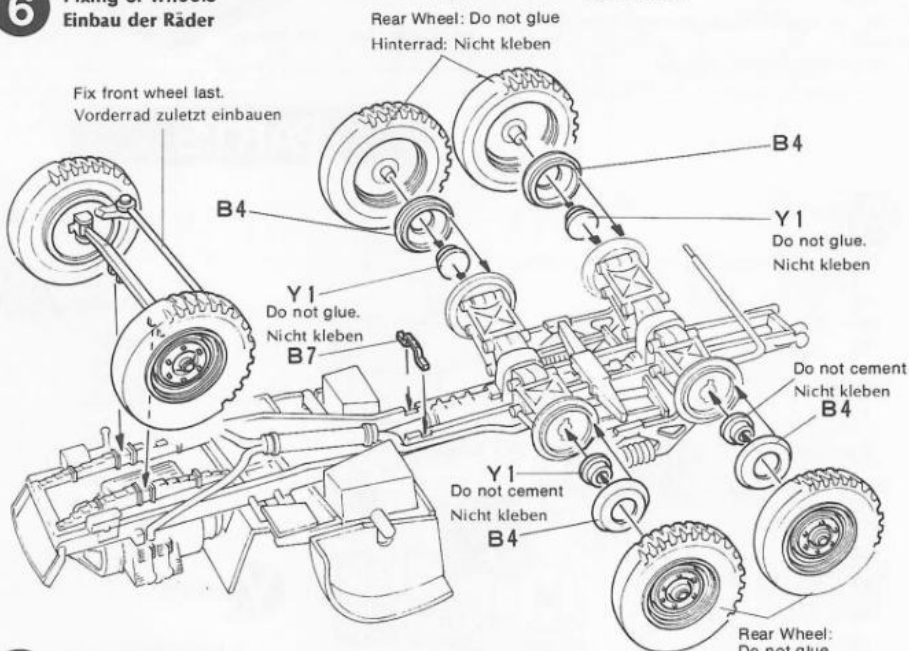

7 Engine Hood
Motorhaube

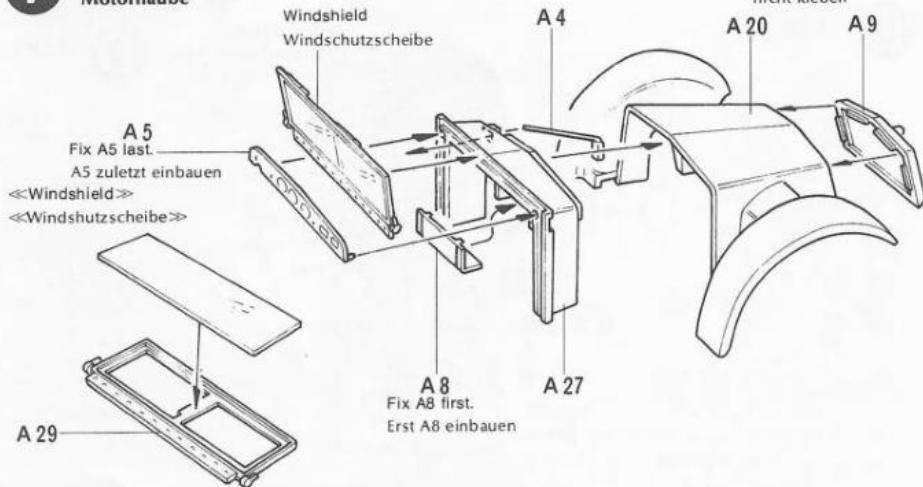

8 <<Cargo>> <<Heckaufbauten>>

There are a lot of similar parts. Make sure of their number and shape.

Viele Teile ähneln sich, auf Nummer und Form achten.

<<Accessory Parts>> <<Zubehörs>>

Parts below can be arranged as you like with difference to the photo on page 8.
Die Zubehörteile können je nach Wunsch eingebaut werden. Siehe Photo Seite 8.

<<5cm light mortar>>
<<leichter Mörser 5 cm>>

Gun Metal D12

D5 D13

Gun Metal <<Kar 98K Rifle>> D3
<<Karabinder 98 K>> D3

Gun Metal
Red Brown

<<Sack>> D20

Buff

<<Jerry Can>>
<<Kanister>>

German Grey
B6

B5

<<Wooden Box>> x 2 B9
<<Holzkisten>> x 2 B9

Matt Earth

<<Panzerschreck>>

Gun Metal
D8 D1
D17

<<MG42>> D6

Gun Metal
Red Brown

<<Ammunition Box>> D9
<<Munitionkästen>> D9

Field Grey

8 Cargo Heckaufbauten

<<Construction 1>>
<<Zusammenbau 1>>

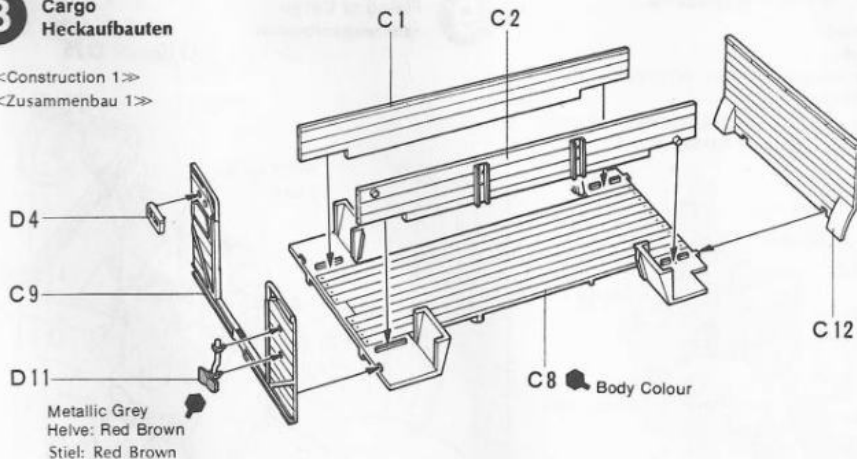

<<Construction 2>>
<<Zusammenbau 2>>

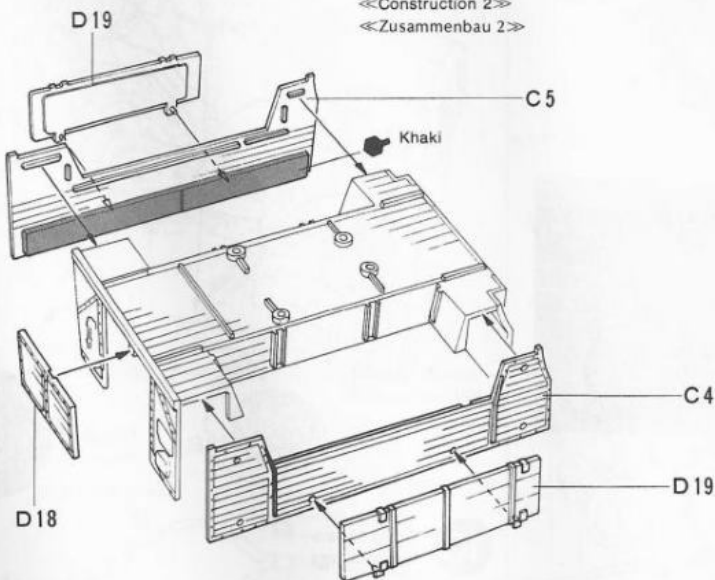

<<Construction 3>>
<<Zusammenbau 3>>

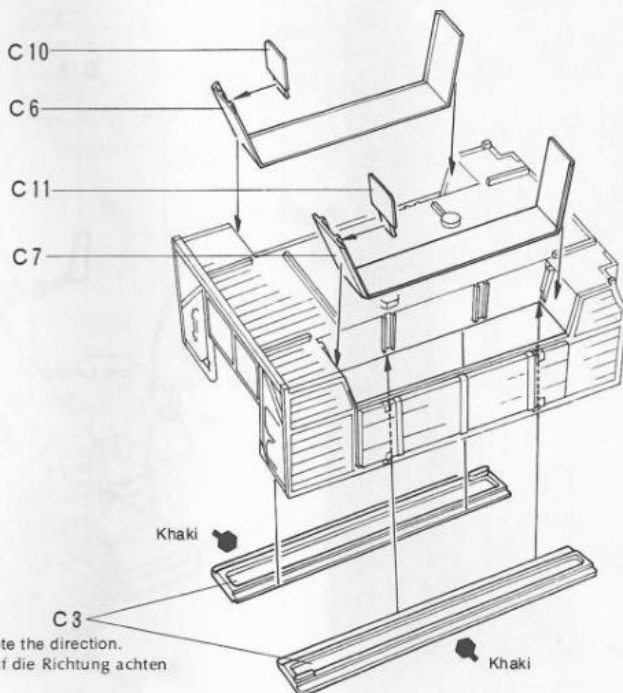

9 <<Fixing of Cargo>>
<<Fahrzeugaufbauten>>

<<Driver>>
<<Fahrer>>
Glue figure's arms in accordance with steering wheel.
Arme dem Steuerrad entsprechend einkleben. Erst Figur bemalen.

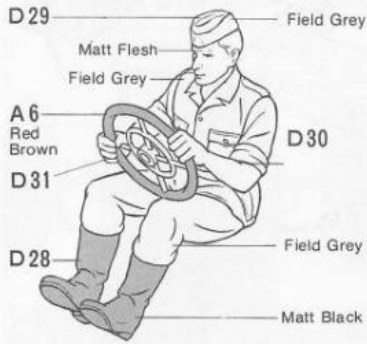

Hold in place with cellophane tape until the adhesive becomes dry.



10 <<Completion>>
<<Endmontage>>

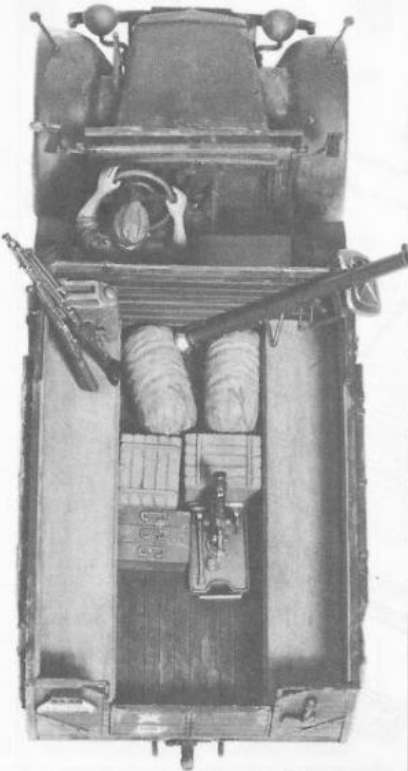

9 Fixing of Cargo
Fahrzeugaufbauten

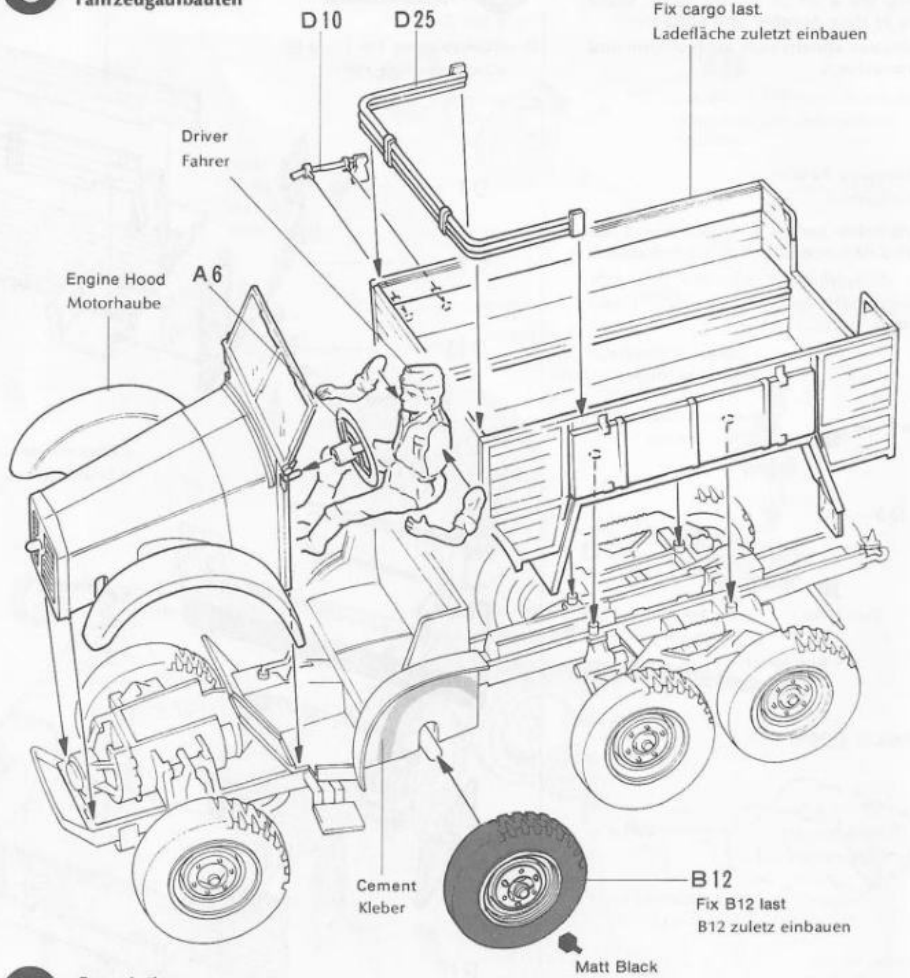

10 Completion
Endmontage

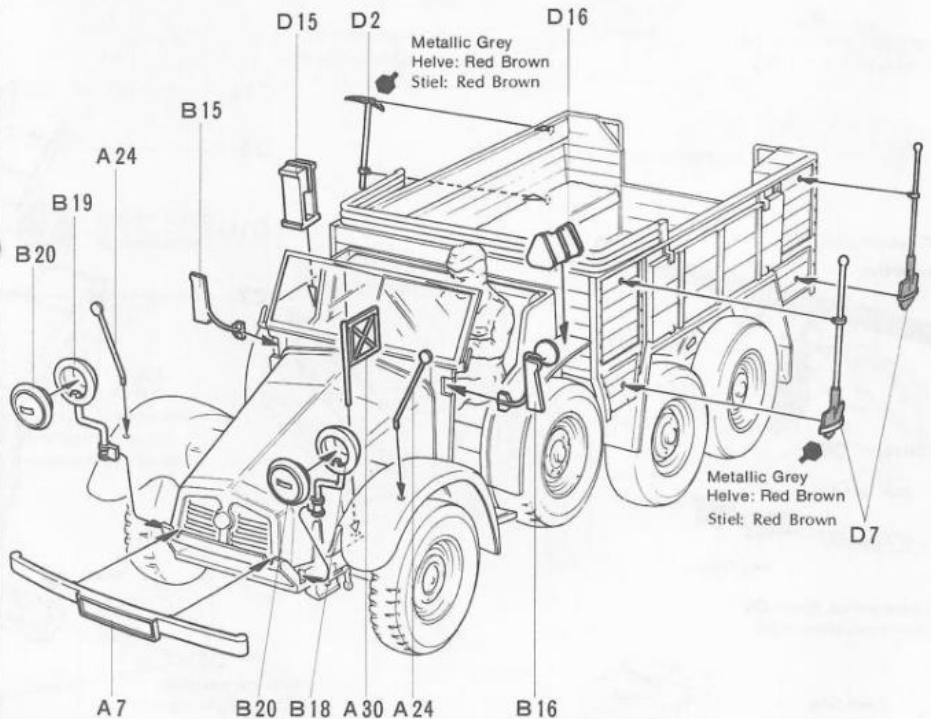

PAINTING APPLYING DECALS

Da die Farben unter der englischen Bezeichnung zu erhalten sind, geben wir nur die englischen Namen an.

Keine Farben auf Nitrobasis verwenden !!! Wir übernehmen keine Haftung für Schäden die durch falsche Farbenwahl entstehen. Nur **Farben verwenden**, die für **Polystyrol Plastik** geeignet sind.

<<Painting of Krupp Protz>>

The Krupp Protz, which showed activity early in World War II from the invasion of Poland in 1939 to the initial stage of the eastern front, was mostly painted German Grey like other vehicles. But some vehicles of this type were painted field Grey. Some of the German Grey vehicles on the Eastern Front were smeared with white paint as a means of winter camouflage.

<<Bemalung>>

Die Krupp Protze stand von 1939 bis zum Ende hauptsächlich im Osten im Einsatz. Die Grundfarbe war Grau. Natürlich wurden je nach Einsatzort Tarnfarben aufgebracht. Im Russland Wintereinsatz wurde z. B. das Fahrzeug einfach weiss übermalt.

★ Refer to page 8 when decals will be applied.

★ Abziehbilder, siehe Seite 8.

<<Accessory Parts>>

<<Zubehör>>

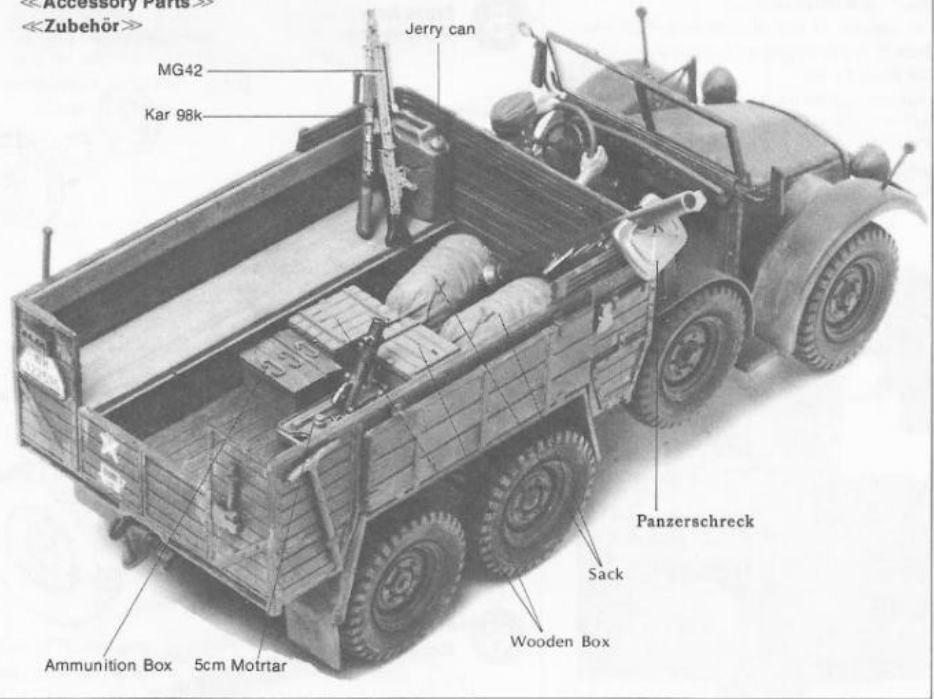

PARTS

A PARTS

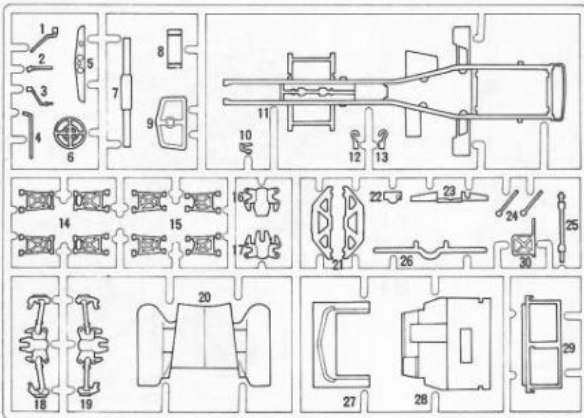

B PARTS

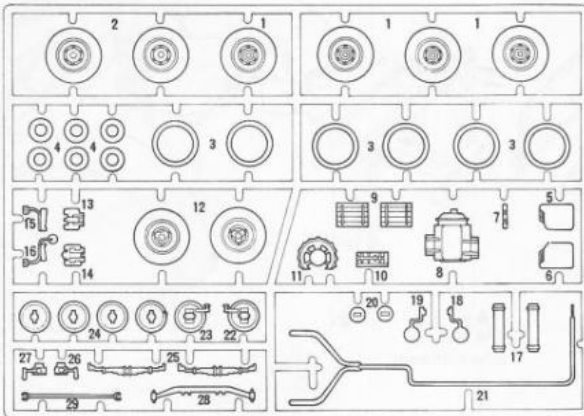

C PARTS

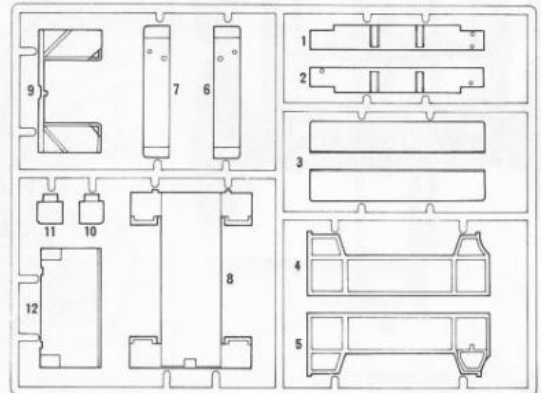

Y PARTS



Windshield
Windschutzscheibe



D PARTS

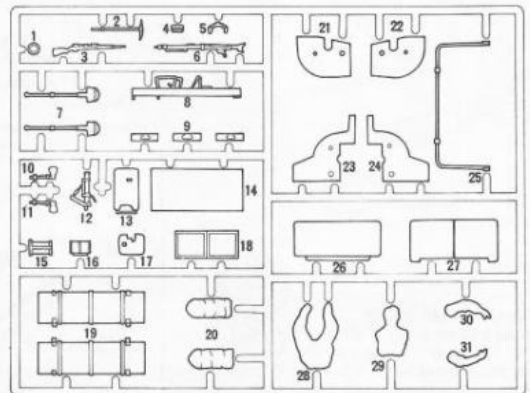

<< Applying Decals >>

<< Abziehbilder >>

Directions for application are given on the reverse side of the decal.

Abziehbilder vorsichtig im Wasser von der Unterlage abschieben, auf richtigen Sitz achten, evtl. Luftblasen herausdrücken und gut trocknen lassen.

Wehrmacht

Vehicle Number	Kfz. No.
WH-122595	WH 122595
WH-182370	WH 182370
Divisional Mark	Div. Zeichen
X 5th Panzer Div.	4th Armored Div.
1st Infantry Div.	21st Infantry Div.
32nd Infantry Div.	46th Infantry Div.
Grossdeutschland Panzer Grenadier Div.	

Die Abziehbilder unten sind in einigen Ländern nicht enthalten.

Vehicle Number	Kfz. No.
- 5537	5537
- 6106	6106
Divisional Mark	Div. Zeichen
G 2nd Panzer Group under the command of Guderian	

Luftwaffe

Vehicle Number	Kfz. No.
WL-135183	WL 135183
Do not apply Divisional and Tactical Marks.	

Tactical Mark

Mechanized Infantry Battalion	Transportation Battalion
Motorcycle Infantry Battalion	Mechanized Artillery Battalion
Anti Tank Gun Battery	

TAMIYA COLOR CATALOGUE

The latest in cars, boats, tanks and ships. Motorized, radio controlled and museum quality models are all shown in full color in Tamiya's latest catalogue. At your nearest hobby supply house.



<< 5th Panzer Division >>

Body Colour: German Grey

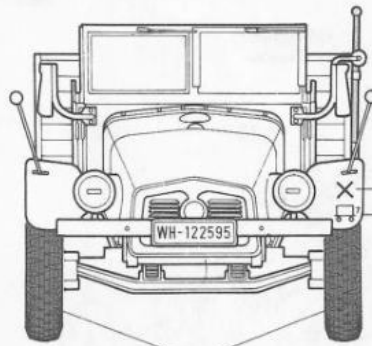

Divisional Mark
Division Zeichen
Tactical Mark
Takt. Zeichen

Matt Black

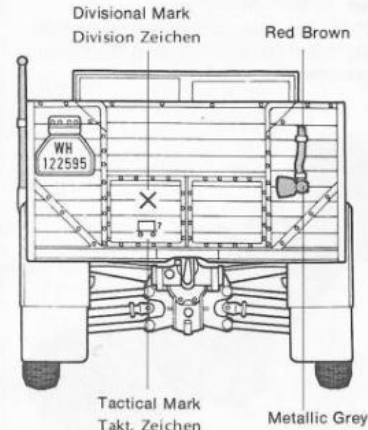

Divisional Mark
Division Zeichen
Red Brown

Tactical Mark
Takt. Zeichen

Metallic Grey

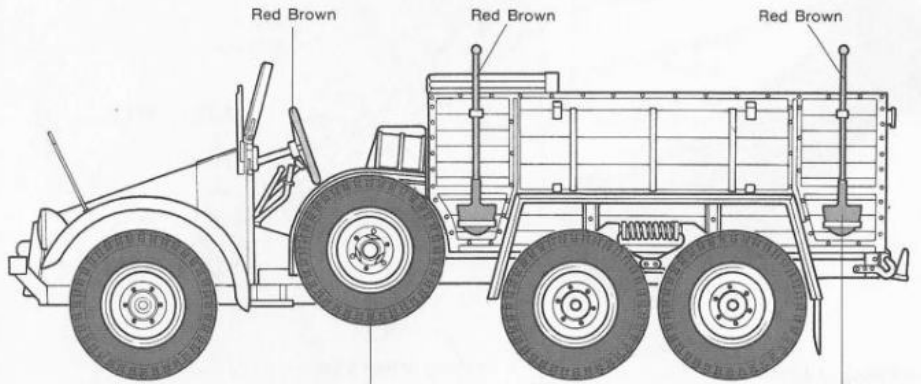

Red Brown

Red Brown

Red Brown

Matt Black

Metallic Grey

<< Panzer Division "Das Reich" >>

Body Colour: German Grey

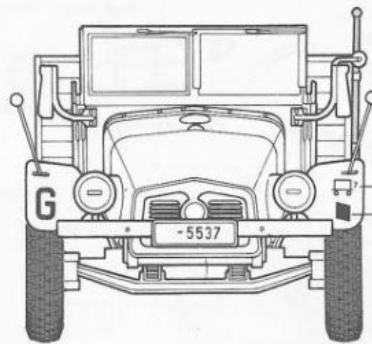

Tactical Mark
Takt. Zeichen
Divisional Mark
Division Zeichen

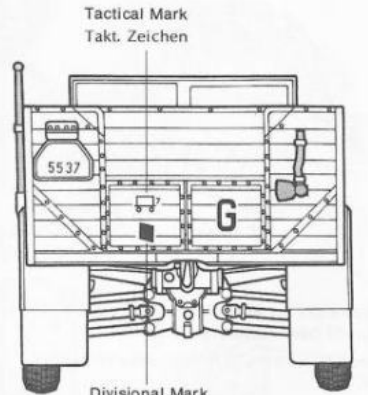

Tactical Mark
Takt. Zeichen

Divisional Mark
Division Zeichen

<< Other Vehicles >>
<< andere Fahrzeuge >>

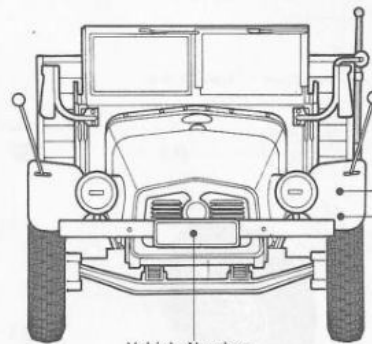

Vehicle Number
Fahrzeug - Nummer
Divisional Mark
Division Zeichen
Tactical Mark
Takt. Zeichen

Vehicle Number
Fahrzeug - Nummer

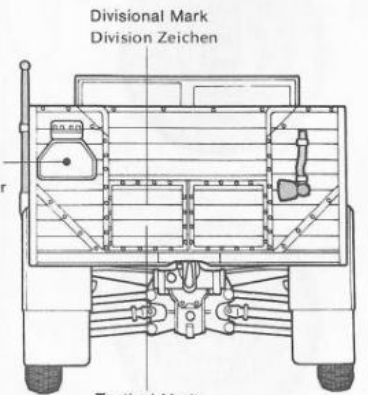

Divisional Mark
Division Zeichen

Tactical Mark
Takt. Zeichen