

PERFECT SCALE MODELLBAU

GEROLD BETZLER
SONNENSTR. 6A
893568 KAMMELTAL

TEL. 0049 (0) 8223 - 960 246
FAX. 0049 (0) 8223 - 960 247
EMAIL: INFO@PERFECT-SCALE.COM
WWW.PERFECT-SCALE.COM

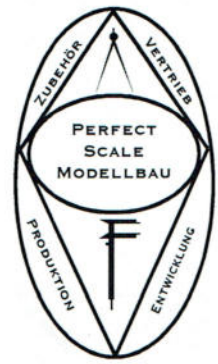

1 TO LASTANHÄNGER 1 / 35

1 TO "NATO TRAILER"

- Dieser Bausatz enthält 42 Bauteile aus Resin, die gemäß dieser Bauanleitung zusammengesetzt werden sollten.
- Nicht im Bausatz enthalten sind Klebstoffe und Farben.
- Der Bausatz ist nicht geeignet für Kinder und Jugendliche unter 14 Jahren.
- Zur Verarbeitung, Entgratung und Säuberung der Bauteile werden Feilen, Schleifpapier und Skalpe empfohlen.
- Vor der Lackierung sollten die Bauteile mit Silikonentferner, oder anderen Entfettungsmitteln behandelt werden, um optimale Bemalungsergebnisse zu erzielen.
- Zur Verarbeitung der Bauteile werden 2 Komponenten Epoxid Harz Kleber, sowie Cyanacrylat Sekundenkleber empfohlen. Die Sicherheits und Warnhinweise der Klebstoffhersteller sollten unbedingt eingehalten werden.
- Leider lassen sich Luft einschüsse und Verformung der Bauteile nicht immer ausschließen. Sollten Bauteile gänzlich unbrauchbar oder total beschädigt sein, so senden Sie uns bitte das fehlerhafte Bauteil zu. Sollten Bauteile fehlen, so bitten wir Sie uns den beiliegenden Kontrollzettel mit der Bauteilnummer zuzusenden.
- Vor dem Zusammenbau können Sie die Vollständigkeit der Bauteile anhand der beiliegenden Teileliste prüfen.

**PERFECT SCALE MODELLBAU UND GEROLD BETZLER WÜNSCHT IHNEN
VIEL SPASS UND VERGNÜGEN MIT DIESEM BAUSATZ**

- This kit contains 42 resin parts which should be assembled according to the following manual.
- Adhesives and paints are not included.
- The kit is not suitable for children and teenagers less than 14 years of age.
- For the processing, cleaning and smoothing of the components we recommend fine sand paper, needle files and scalpels.
- It is necessary to treat all parts with grease remover or degreasing substances to achieve optimal painting results.
- For assembling the parts one has to use 2 component Epoxi Glue and Cyanacrylat adhesive. The safety and warning notes of the adhesive manufacturers should be adhered absolutely.
- Unfortunately, air bubbles and deformations of the parts can not be always excluded. However, if components should be useless or totally damaged, so please send the parts to our office for replacement. In case that components are missing, please send us the included quality control note with the part number.
- Before assembling the parts please check the parts by the included list.

**WE WISH YOU HAPPY MODELLING AND LOTS OF FUN WITH YOUR HOBBY.
YOUR GEROLD BETZLER**

PERFECT SCALE MODELLBAU

- TEILELISTE 1 TO. LASTANHÄNGER 1: 35

1 TO LASTANHÄNGER

1. LADEBORDWAND VORNE 1 X



2. LADEBORDWAND HINTEN 1 X



3. LADEBORDWAND LINKS 1 X

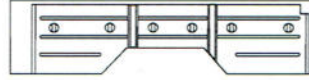

4. LADEBORDWAND RECHTS 1 X



5. KOTFLÜGEL
LINKS 1 X

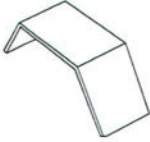

6. KOTFLÜGEL
RECHTS 1 X



7. LADEFLÄCHE 1 X

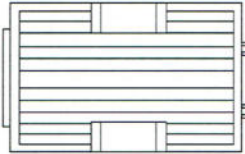

8. RAHMEN
RECHTS 1 X

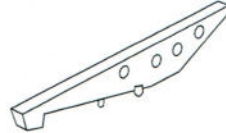

9. RAHMEN
LINKS 1 X

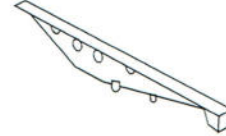

10. RAHMENQUERTRÄGER
MITTE 1 X



11. RAD 2 X



12. RESERVERAD 1 X



13. ZUGGABEL 1 X

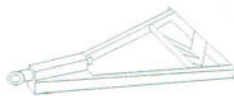

14. ACHSE 1 X



15. UNTERLEG-
KEIL 2 X



16. LEITKREUZ 1 X



17. ABDECKPLATTE VORNE
LINKS 1 X



18. ABDECKPLATTE VORNE
RECHTS 1 X



19. BREMSTROMMEL 2 X



20. STAUKASTEN
LINKS 1 X



21. STAUKASTEN
RECHTS 1 X



22. STANDFUSS
STÜTZE 2 X



23. ANHÄNGER-
KUPPLUNG 1 X



24. RÜCKLEUCHE 2 X



25. REFLEKTOR
HINTEN 2 X



26. ZUGÖSE 1 X



27. GELENK
ZUGÖSE 1 X



28. STÜTZRAD
VORNE 1 X



29. STÜTZE
HINTEN 2 X



30. FESTSTELL-
BREMSE 1 X



31. BREMSENMECHANIK 1 X



32. ERSATZRAD-
HALTERUNG 1 X



33. PLANE 1 X

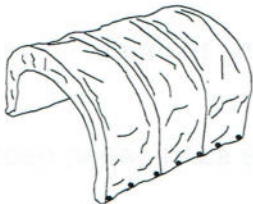

34. TARNLICHT 1 X



35. HALTERUNG
ANHÄNGERKUPPLUNG 1 X



QUALITÄTSKONTROLLE / QUALITY CONTROL:

**FALLS BAUTEILE FEHLEN SOLLTEN, ODER
UNBRAUCHBAR SIND, SO SENDEN SIE BITTE DIESES
FORMBLATT MIT DEN BESCHÄDIGTEN BAUTEILEN UND DER TEILENUMMER
AN UNSER BÜRO.**

**IF ANY PARTS ARE MISSING, OR IF ANY PARTS ARE UNWORKABLE PLEASE
SEND THIS FORM TOGETHER WITH THE DAMAGED PARTS TO OUR OFFICE.**

FEHLENDE TEILE / MISSING PARTS:

BESCHÄDIGTE TEILE / DAMAGED PARTS:

**ANHÄNGER
TRAILER**

TEIL 7
PART 7

WHLWEISE, OFFEN ODER GESCHLOSSEN
OPTIONAL, OPEN OR CLOSED

TEIL 3
PART 3

TEIL 79
PART 79

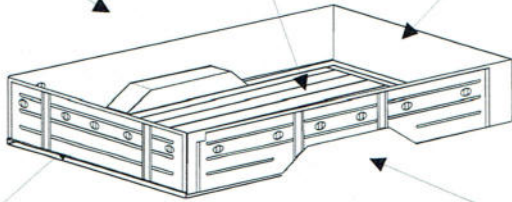
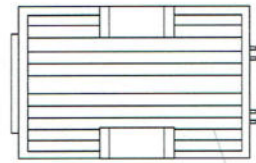
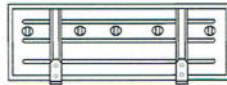
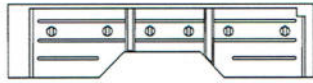

TEIL 1
PART 1

TEIL 4
PART 4

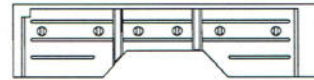
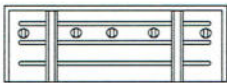

ANSICHT VON UNTEN
VIEW FROM DOWNSIDE

TEIL 6
PART 6

TEIL 8
PART 8

TEIL 32
PART 32

TEIL 12
PART 12

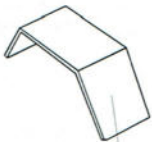

TEIL 7
PART 7

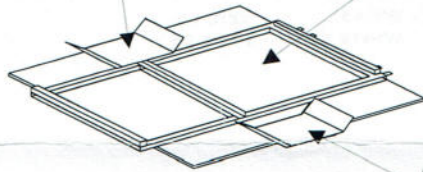
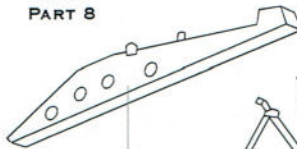

TEIL 5
PART 5

TEIL 35
PART 35

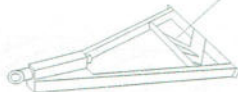
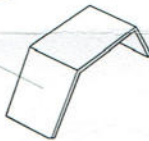

TEIL 13
PART 13

TEIL 10
PART 10

TEIL 9
PART 9

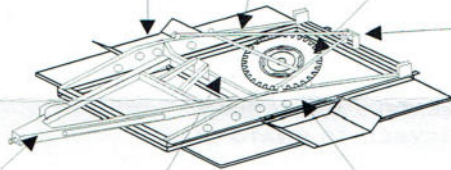

FAHRZEUG GRUNDFARBE:
REVELL 46 "NATO OLIV"
VEHICLE BASECOLOR
REVELL 46 "NATO OLIVE"

WHLWEISE, AUSGEKLAPPT ODER EINGELAPPT
OPTIONAL, IN OR OUT

TEIL 21
PART 21

TEIL 18
PART 18

TEIL 14
PART 14

TEIL 20
PART 20



TEIL 28
PART 28

TEIL 11
PART 11

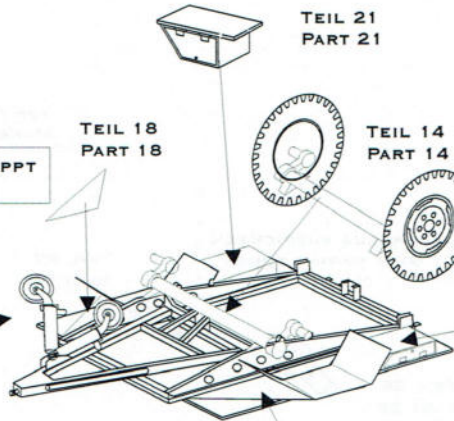

TEIL 17
PART 17

SCHWARZ
BLACK

TEIL 19
PART 19

TEIL 14
PART 14

TEIL 19
PART 19



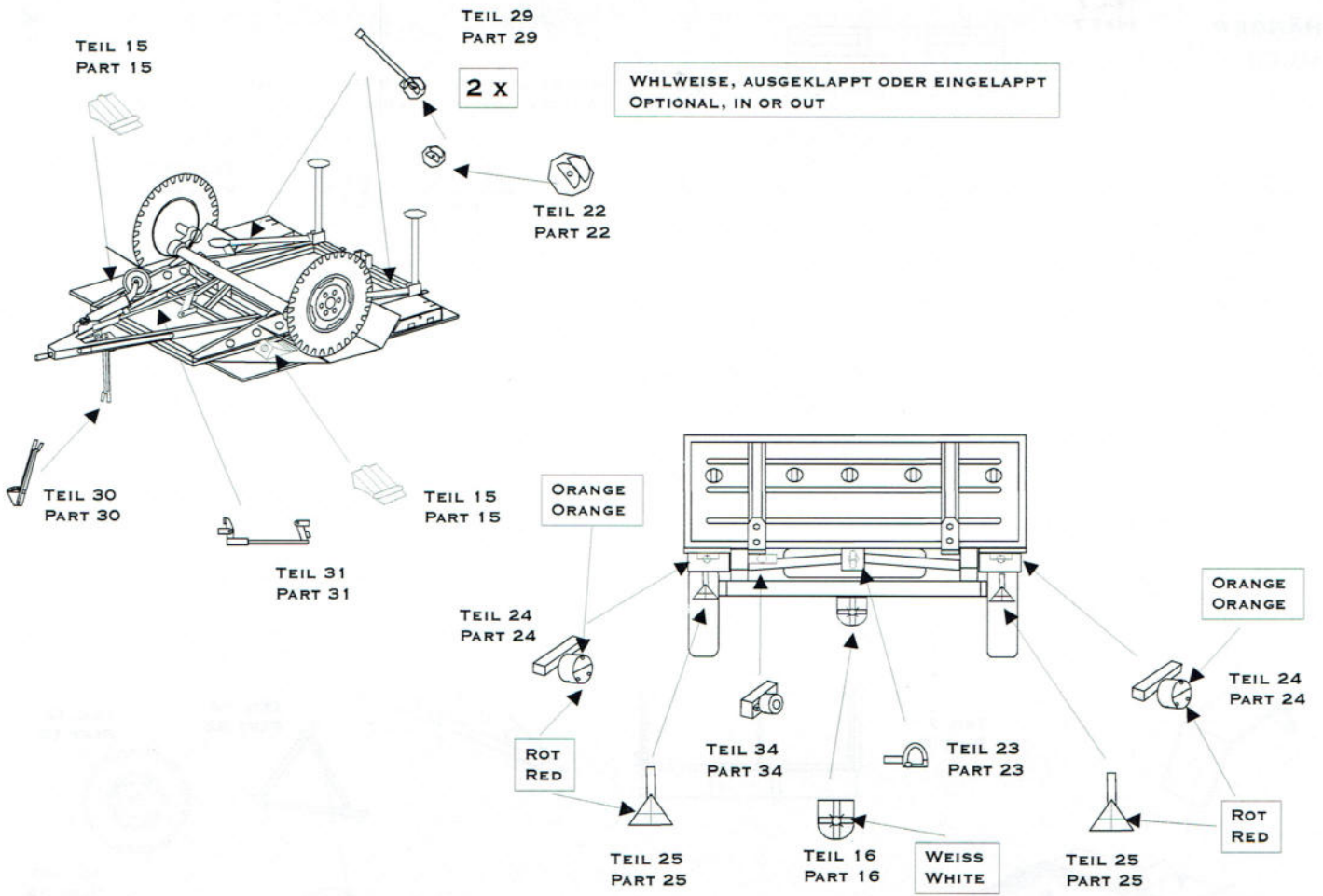

Fahrzeug Grundfarbe:
REVELL 46 "NATO OLIV"
VEHICLE BASECOLOR
REVELL 46 "NATO OLIVE"

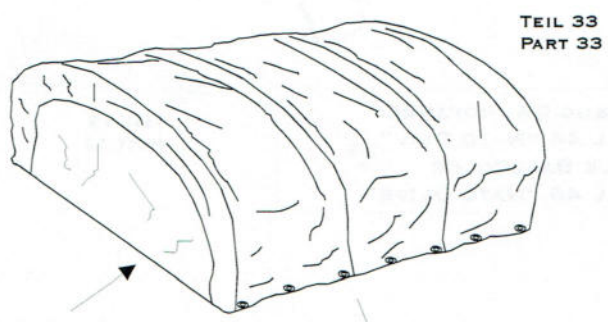

MIT ZUGFAHRZEUG AUSRICHTEN
MAKE FIT WITH TOWING TRUCK

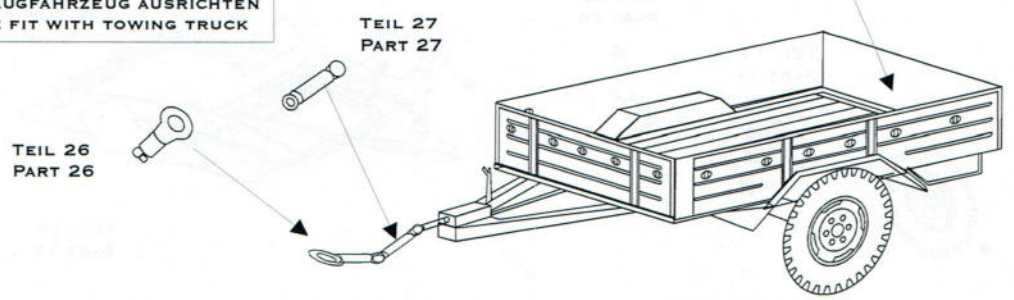

HAPPY MODELLING